



RiverCruising.co.uk

THE RIVER CRUISE EXPERTS

FOR THE LATEST PRICES AND AVAILABILITY
CALL OUR TEAM ON **0800 810 8262**

TO ORDER A COPY OF THIS BROCHURE
EMAIL: **BROCHURES@RIVERCRUISING.CO.UK**

(BROCHURES SUBJECT TO STOCK)



VIKING
Exploring the World in Comfort®

2025 RIVER JOURNEYS

PLUS 2025 OCEAN JOURNEYS





THE
TRAVEL AWARDS
2023
THE Financial TIMES THE Sunday TIMES
TIMES Travel L U X X

WINNER
BEST RIVER CRUISE OPERATOR







CONTENTS

FOR THE THINKING PERSON™	6
RIVER JOURNEYS	8
VIKING RIVER SHIPS	10
RIVER DESTINATIONS	26
MISSISSIPPI EXPERIENCES	42
DECK PLANS	44
OCEAN JOURNEYS	50
VIKING OCEAN SHIPS	52
OCEAN DESTINATIONS	72
DECK PLANS	86
BOOKING CONDITIONS	88



VIKING

FOR THE THINKING PERSON™

Created for curious, experienced travellers

WE ALL TRAVEL TO EXPLORE, TO LEARN, TO UNDERSTAND. At Viking, we believe travel should be more than just a trip—it should be a doorway to cultural insight and personal enrichment. That is why our itineraries are designed to help you explore and engage with your destination through its food, culture, countryside and customs.

BEFORE you travel, we provide you with materials to help you plan and anticipate your journey, from filmographies that inspire wanderlust to recommended reading that informs and enlightens.

ONBOARD activities are designed for enrichment and renewal. We offer lectures on history and art, cooking demonstrations of regional favourites, menus offering local cuisine and more.

ON SHORE, you might accompany the ship's chef to a local market; go behind the scenes at a famous theatre company; tour a glassblower's workshop; or view a museum's private collection.

CONNECT with like-minded travellers on board ships designed for comfort and an ease of discovery. Our aim is to help you feel more connected — to newfound friends and the world.



VIKING EXPLORER SOCIETY MEMBERSHIP

Once you have returned from your first Viking journey, you will automatically be invited to join the Viking Explorer Society which entitles you to an extra £100pp discount on all future voyages.



As a member of ABTA, Viking is a fully bonded and licensed tour operator. All the flights and flight-inclusive holidays in this brochure are financially protected by the ATOL scheme. When you pay you will be supplied with an ATOL Certificate. Please ask for it and check to ensure that everything you booked (flights, hotels and other services) is listed on it. Please see our booking conditions for further information, or for more information about financial protection and the ATOL Certificate go to: www.atol.org.uk/ATOLCertificate





RIVER JOURNEYS

RHINE • MAIN • DANUBE

SEINE • RHÔNE • GARONNE

ELBE • DOURO • MEKONG • NILE

MISSISSIPPI

For 25 years, we have set the standard for river journeys, with our destination-focused and culturally enriching itineraries on the great waterways of Europe, Egypt and Southeast Asia.

These seamless journeys bring you closer to history as you sail past extraordinary landscapes into the centre of charming villages and iconic cities.



VIKING LONGSHIPS

Award-winning, state-of-the-art sister ships

GUESTS: 190 LENGTH: 443 FT. DECKS: 4 STATEROOMS: 95

Solar Panels

Help make our ships the greenest on the rivers.

Walking Track

The perfect place for exercise and taking in fresh air.

Viking Lounge

Linger over the tunes from a baby grand piano while comparing notes about the day's discoveries with new friends.

2 Explorer Suites

Feature 445 square feet, separate sleeping and sitting rooms and a private wraparound veranda with 270° views.

Organic Herb Garden

A delightful green space that enhances your cuisine with fresh, just-picked flavour.

Energy-Efficient Hybrid Engines

Reduce vibrations for a remarkably smooth ride with no motion sickness.

7 Veranda Suites

Feature 275 square feet on the Upper Deck, separate sleeping quarters with a French balcony and sitting room with a full veranda.

39 Full-Size Veranda Staterooms 22 Staterooms with French Balconies

The largest deluxe staterooms afloat on Europe's rivers.

Atrium

Our soaring lobby, awash in light, where our Guest Services staff can help you customise your explorations ashore.

Library

Read up on your next destination with our thoughtfully curated book collection.



Since their launch, the Viking Longships have received acclaim for their innovative design, outstanding quality and state-of-the-art engineering. These are the things that distinguish Viking from all other river cruise lines, and make the Viking Longships the most admired and awarded in the world. Our river cruise fleet has grown to more than 60 ships, each an elegant hotel that is both stylish and comfortable.

Viking Bar

Enjoy a drink or coffee and settle in to see the beautiful scenery.

Floor-to-Ceiling Windows

Maximise natural light and create a light, airy ambience.

Complimentary Wi-Fi

Stay connected with the world around you.

Sun Deck

Relax outdoors, in the sunshine or under an umbrella, and watch the ever-changing panoramas.

Aquavit Terrace®

Dine *al fresco* in a glorious outdoor seating area at the bow of the ship.

The Restaurant

Enjoy always available international classics, regional cuisine and personalised service in an elegant setting.





THE AQUAVIT TERRACE, VIKING LONGSHIP



THE LOUNGE, VIKING LONGSHIP

SERENE SCANDINAVIAN SPACES

Every room is beautiful and functional, quiet and filled with light

VIKING HAS FINE-TUNED THE ART OF EXPLORING THE WORLD in understated elegance. Our ships have been thoughtfully engineered by experienced nautical architects to help you connect with your destination in every way. Graceful rooms were designed for your comfort and serenity, and light-filled spaces inspire and refresh you throughout your journey.

WE HAVE DESIGNED OUR SHIPS DOWN TO THE MOST MINUTE DETAIL—from the light and airy Atrium, our soaring lobby that rivals those of the finest hotels, to the quiet corner of the Library, a perfect place to read up on your next destination. In the sun-filled Viking Lounge, portions of the floor-to-ceiling windows roll away to bring fresh air in. Step over the threshold, and you will experience the Aquavit Terrace on the Viking Longship. This glorious outdoor seating area at the bow of the ship provides the most *al fresco* dining on Europe's rivers. Have a casual meal here, meet friends for drinks and enjoy breathtaking views of Budapest's Parliament building on the Danube or medieval hilltop castles along the Rhine. Or enjoy a multicourse meal in The Restaurant, our elegant dining venue with panoramic windows that welcome ever-changing views.

On top of the ship, relax on the Sun Deck while you take in 360° views. Exercise *en plein air* on our walking track. And enjoy the fragrances of our onboard herb garden, harvested daily by our culinary staff.

THE LIBRARY, VIKING LONGSHIP





VIKING LONGSHIP, COLOGNE, GERMANY

PURPOSE-BUILT SHIPS

River vessels that bring you closer to your destination

At Viking, we build innovative ships that are the right size for the experience— with a signature Scandinavian design that never upstages the destination.

INTIMATE RIVER VESSELS with all the amenities of an elegant boutique hotel, including an unparalleled choice of all-outside staterooms, expansive views from floor-to-ceiling windows and *al fresco* dining.

WE HAVE DESIGNED OUR RIVER SHIPS to be the most elegant vessels that use the available space in the most effective way—which explains why we are known as the small ship experts. From the space-saving square bow to the patented asymmetrical corridor design, our revolutionary and award-winning Viking Longships have been designed to enhance your journey.



THE LOUNGE, VIKING LONGSHIP

UNDERSTATED ELEGANCE

Modern ships designed for comfort and discovery

Created by interior architects who have designed some of the world's finest hotels, the signature Scandinavian design of our ships celebrates our Nordic heritage: clean lines, colourful woven textiles and light woods that evoke the original Viking explorers' connection to the natural world. Public spaces are light-filled, airy and quiet; staterooms feature thoughtful amenities, including heated bathroom floors, anti-fog mirrors and luxury bed linens; and throughout each ship you will find great attention to detail in leather handrails, original Nordic artwork and libraries stocked with books curated by London bookshop Heywood Hill.



INSPIRING CUISINE

THE FLAVOURS OF YOUR DESTINATION

Experiencing a culture through its food and wine

A GREAT JOY OF TRAVEL lies in sampling the fresh fare and culinary traditions for which a place is known. Locally sourced ingredients—such as Norwegian salmon, Dutch Gouda and Hungarian paprika—inspire our highly trained chefs to create authentic regional dishes on every itinerary. And our thoughtful wine list enhances your meal, with handpicked selections and onboard tastings that showcase an area’s quintessential varietals.

DINING ON A VIKING SHIP, you will find the ideal setting for impeccable service and casual elegance. On our European river vessels, choose between our main dining room, The Restaurant, and the indoor/outdoor Aquavit Terrace. Across our fleet, we offer the most *al fresco* dining on any waterway, so you always have the option to enjoy a meal or a glass of wine while completely surrounded by the scenery.

*Please note, there is no *al fresco* dining on our Viking Longships on Douro River.



THE RESTAURANT, VIKING LONGSHIP

OUR VIKING FAMILY

Thoughtful attention from dedicated staff

ONLY THE VERY BEST. Our knowledgeable and highly experienced Swiss management oversees your entire journey and handpicks each member of our onboard team. Rigorous training and inspiring leadership have also made Viking the employer of choice.

A WARM WELCOME. We are dedicated to ensuring everyone feels at home on board our ships. We have the most loyal staff in the industry—with more than 90% returning year after year—so you can expect familiar faces and the same quality service every time you travel with us.



COOKING DEMONSTRATION

ONBOARD ENRICHMENT

Bringing culture and history to life

GUEST LECTURERS expertly shed light on your destination's history, art, architecture and more—from the formation of the European Union to the intricacies of Viennese coffee culture.

PORT TALKS provide an overview of the next day's port of call through informative multimedia presentations.

DESTINATION PERFORMANCES showcase the most iconic cultural performing arts of the region, such as German folk music and Portugal's *fado*.

COOKING DEMONSTRATIONS present recipes of regional treats and drinks—from Austrian apple strudel to Rudesheim Coffee.

CRAFT DEMONSTRATIONS reveal centuries-old traditions of local artisans, such as glassblowing, lace making and wooden shoemaking.

WINE TASTINGS introduce you to a wide selection of regional varietals or vintages. Train your palate on everything from French Bordeaux to Spanish Garnacha.



KARINE HAGEN AT SCHLOSS LÖWENSTEIN, GERMANY

ONSHORE EXPERIENCES

Designed to take you closer, The Viking Way[®]

THE VIKING WAY OF EXPLORATION offers behind-the-scenes insights and opportunities that set us apart from other travel companies. While we feature the expected and iconic—such as visits to renowned museums and notable landmarks—we also offer our guests **LOCAL LIFE**, **WORKING WORLD** and **PRIVILEGED ACCESS[®]** experiences, opening doors to places otherwise difficult to visit.

Karine Hagen, Executive Vice President of Viking, has travelled the globe to develop these Viking Way experiences—and has captured some of them in a series of Destination Insights videos, which are available on our website, as well as our award-winning enrichment channel, **Viking.TV**. In addition to daily livestreams and hundreds of archived video sessions, guests have access to an extensive library of content to inform them about their upcoming journey and encourage deeper engagement while travelling.



AQUAVIT TERRACE ON THE VIKING LONGSHIPS

Revolutionary in concept and design, the Aquavit Terrace is a glorious outdoor seating area at the bow of the ship. Dine, get to know new friends or simply watch Europe's picturesque riverscapes unfold before you in this inviting and refreshing space that brings your destinations close enough to touch.



AQUAVIT LOUNGE® ON THE VIKING LONGSHIPS

Peaceful, serene and casual, the bright Aquavit Lounge is the perfect place to sip regional wine and read a book or watch the scenery pass by. Floor-to-ceiling windows slide open to the outdoor Aquavit Terrace, welcoming in the fresh air and bringing the river's banks into sharper focus.

Please note, there is no *al fresco* dining on our Viking Longships on Douro River.



DESTINATION-FOCUSSED CUISINE

VIKING INCLUSIVE VALUE

Pricing that covers everything you need—and nothing you do not

At Viking, we firmly believe that you should not have to incur an expense every time you want a cup of coffee, a glass of wine or an excursion ashore. Instead, our goal is to provide you with great value, so we have designed our voyages to give you more for your money with a fare that includes:

- Return economy* scheduled flights from London and up to 10 regional airports
- One shore excursion in almost every port of call, led by a knowledgeable local guide
- Free Wi-Fi on board (connection speed may vary)
- All onboard meals featuring regional specialties & always available classics
- Beer, wine & soft drinks with onboard lunch & dinner
- 24-hour specialty coffees & teas
- Visits to UNESCO World Heritage Sites
- Enrichment lectures & destination performances
- All port taxes & fees
- Overseas ground transfers
- Onboard gratuities
- Viking is a member of ABTA and is ATOL licensed

Plus, additional tools and services available to assist with travel planning include:

- Online booking to price & build your voyage in just a few steps
- **MY VIKING JOURNEY** online guest portal to select shore excursions, make dining reservations and personalise your voyage in advance of travel

*Free business class upgrade applies to Explorer Suite stateroom on European Viking Longships only.

CHEF



VIKING
CRUISES



ENVIRONMENTALLY FRIENDLY VIKING LONGSHIPS

ENVIRONMENTALLY CONSIDERATE

Reducing impact through design & technology

ALL VIKING LONGSHIPS are powered by true diesel-electric hybrid engines that meet stringent emission standards and reduce vibrations for a remarkably smooth ride. Key features of the ships' energy-efficient design include:

- **EFFICIENT USE OF SPACE.** On a ship, every bit of added weight results in extra fuel consumption. This is why we are careful to add only what is needed to our ships, prioritising optimal guest comfort and operational efficiency.
- **SHORE POWER.** Viking Longships utilise shore power where possible to reduce reliance on fuel while in port. This feature is already providing a reduction in CO₂ emissions of up to 30% on some itinerary sections.
- **BATTERY PACKS.** Our newest Viking Longships have battery packs installed on board, which are expected to reduce our emissions by an additional 5%.
- **LED LIGHTING.** The lighting instruments on board Viking Longships are more energy-efficient LEDs, utilising low wattage and therefore lower heat output, lower power usage and a longer life.
- **SOLAR PANELS.** Located on the Sun Deck, these onboard solar panels help make Viking Longships the greenest vessels on the rivers of Europe.



Beyond the technical aspects of the ships' design, Viking Longships are also equipped with the following features to reduce environmental impact:

- **ADVANCED RECYCLING & WASTE MANAGEMENT.** In addition to trash and recycling separation facilities, Viking Longships are equipped with a "zero" discharge wastewater treatment system making them environmentally safe for any river they sail.
- **NOISE & LIGHT REDUCTION.** Our vessels feature state-of-the-art insulation to ensure the overwater noise from on board is kept to a minimum, keeping local life undisturbed. On board lighting has also been designed to ensure no light pollution is disturbing local fish and wildlife.
- **BIODIVERSITY-SUPPORTING DOCKING LOCATIONS.** With more than 60 Viking-owned docking locations, specifically designed for Viking Longships, we provide an infrastructure that has close to zero impact on biodiversity.

THE WORLD OF VIKING

River Destinations

Wherever you choose to go—Europe, Egypt, Southeast Asia, the Mississippi or beyond—Viking takes you to places you can only fully appreciate by river, and takes you there in comfort.







PARIS & THE HEART OF NORMANDY

Paris roundtrip | 8 days | Mar-Nov 2025 departures | From £2,495 per person

Dock in the heart of Paris, admiring views of the Eiffel Tower and a replica of the Statue of Liberty from your ship. Experience history first-hand at the Normandy beaches and delight in Rouen's Gothic architecture. Explore Giverny and the charming house and gardens where Claude Monet lived and worked, the setting inspiring many of his masterpieces. This voyage celebrates history, art, food and customs in France's most alluring urban and pastoral settings.

DAY	DESTINATION	Viking Longships—Seine Mar–Nov 2025 departures	STANDARD	FRENCH BALCONY	VERANDA	VERANDA SUITE	EXPLORER SUITE
1-2	PARIS, FRANCE	Mar pricing per person from: with £1,000pp saving	£2,495	£3,495	£3,895	£5,595	£8,295
3	LA ROCHE-GUYON, FRANCE	Apr pricing per person from: with £1,000pp saving	£2,895	£3,695	£4,395	£6,095	£8,295
4	SCENIC SAILING: SEINE RIVER	May pricing per person from: with £1,000pp saving	£3,195	£4,695	£5,295	£7,595	£9,995
5	NORMANDY BEACHES, FRANCE	Jun pricing per person from: with £1,000pp saving	£3,095	£4,395	£4,895	£6,895	£8,795
6	LES ANDELYS, FRANCE	Jul-Aug pricing per person from: with £1,000pp saving	£2,695	£3,795	£4,295	£5,895	£7,895
7	PARIS (LE PECQ), FRANCE	Sep pricing per person from: with £1,000pp saving	£3,195	£4,695	£5,295	£7,595	£9,995
8	PARIS, FRANCE	Oct pricing per person from: with £1,000pp saving	£2,695	£3,595	£4,095	£6,095	£7,995
	One complimentary shore excursion in almost every port of call.	Nov pricing per person from: with £1,000pp saving	£2,595	£3,195	£3,595	£5,295	£6,895

Terms and conditions: Prices and availability are correct at the time of going to print but are subject to change. Prices are per person based on double occupancy and include an early booking discount of £1,000pp. £1,000pp early booking discount is only valid on 2025 European river journeys. This offer applies to new bookings only and is valid until 30 June 2024. From prices are based on the lowest stateroom grade available for each category. From prices are based on the lowest priced departure date within the month. Some departure dates within the same month may be at a higher cost. Gratuities included on board ship only. Single supplements: F-E 50%, D-ES 100%. Please see back page for full terms and conditions.

LEFT: VIKING LONGSHIP, EIFFEL TOWER
RIGHT: MONET'S GARDEN AT GIVERNY, FRANCE



GRAND EUROPEAN TOUR

Amsterdam to Budapest | 15 days | Apr-Nov 2025 departures | From £4,095 per person

Admire Rhine Valley vistas from a 900-year-old castle. Sample the food and wine of Austria’s Wachau Valley. Learn the Viennese waltz, and linger in Budapest’s Café Gerbeaud. Indulge all your senses on this 15-day journey spanning the best of Europe.

Our most iconic itinerary traces the Rhine, Main and Danube Rivers between the windmill-dotted waterways of the Netherlands and the stunning landscapes of Hungary, with engaging encounters at every bend.

DAY	DESTINATION	Viking Longships—Seine Apr–Nov 2025 departures	STANDARD	FRENCH BALCONY	VERANDA	VERANDA SUITE	EXPLORER SUITE	
1	AMSTERDAM, THE NETHERLANDS	Apr pricing per person from: with £1,000pp saving	£4,095	£6,095	£6,895	£9,695	£12,095	
2	KINDERDIJK, THE NETHERLANDS	May pricing per person from: with £1,000pp saving	£4,895	£6,795	£7,495	£10,495	£12,895	
3	COLOGNE, GERMANY	Jun pricing per person from: with £1,000pp saving	£4,895	£6,795	£7,495	£10,495	£12,895	
4	KOBLENZ, GERMANY	Jul-Aug pricing per person from: with £1,000pp saving	£4,095	£5,995	£6,795	£9,695	£12,095	
5	SCENIC SAILING: MAIN RIVER, SPESSART	Sep pricing per person from: with £1,000pp saving	£4,895	£6,795	£7,495	£10,495	£12,895	
6	WÜRZBURG, GERMANY	Oct pricing per person from: with £1,000pp saving	£4,495	£6,395	£7,095	£10,095	£12,495	
7	BAMBERG, GERMAN	Nov pricing per person from: with £1,000pp saving	£4,095	£5,995	£6,795	£9,695	£12,095	
8	NUREMBERG, GERMANY	Terms and conditions: Prices and availability are correct at the time of going to print but are subject to change. Prices are per person based on double occupancy and include an early booking discount of £1,000pp. £1,000pp early booking discount is only valid on 2025 European river journeys. This offer applies to new bookings only and is valid until 30 June 2024. From prices are based on the lowest stateroom grade available for each category. From prices are based on the lowest priced departure date within the month. Some departure dates within the same month may be at a higher cost. Gratuities included on board ship only. Single supplements: F-E 50%, D-ES 100%. Please see back page for full terms and conditions.						
9	REGENSBURG, GERMANY							
10	PASSAU, GERMANY							
11	MELK, AUSTRIA							
12-13	VIENNA, AUSTRIA							
14-15	BUDAPEST, HUNGARY							

One complimentary shore excursion in every port of call.
Some departures are in the reverse direction.
This itinerary is also available in the reverse direction.

LEFT: VIKING LONGSHIP IN BUDAPEST, HUNGARY
RIGHT: WACHAU VALLEY, AUSTRIA



PORTUGAL'S RIVER OF GOLD

Lisbon to Porto | 10 days | Mar-Nov 2025 departures | From £3,495 per person

Experience the renaissance of Lisbon, newly invigorated with trending galleries and restaurants. Explore two of Iberia's oldest university towns: Coimbra, Portugal and Salamanca, Spain. Roam the port warehouses of Porto. Enjoy traditional cuisine, wine and *fado* singing. Sail the Douro River Valley, the world's oldest demarcated wine region and a UNESCO World Heritage Site.

Our 10-day itinerary includes a hotel stay in Lisbon and the added bonus of a visit to Spain.

DAY	DESTINATION	Viking Longships—Douro Mar–Nov 2025 departures	STANDARD	FRENCH BALCONY	VERANDA	VERANDA SUITE
1-2	LISBON, PORTUGAL	Mar pricing per person from: with £1,000pp saving	£3,745	SOLD OUT	£5,695	SOLD OUT
3	PORTO, PORTUGAL	Apr pricing per person from: with £1,000pp saving	£3,995	SOLD OUT	£6,195	£7,895
4	RÉGUA & PINHÃO, PORTUGAL	May pricing per person from: with £1,000pp saving	£4,295	£6,395	£6,695	£8,695
5	SCENIC SAILING: DOURO RIVER & BARCA D'ALVA, PORTUGAL	Jun pricing per person from: with £1,000pp saving	£3,995	SOLD OUT	£6,195	£7,495
6	SALAMANCA, SPAIN	Jul-Aug pricing per person from: with £1,000pp saving	£3,495	£5,195	£5,395	£6,095
7	PINHÃO, PORTUGAL	Sep pricing per person from: with £1,000pp saving	£4,095	£6,295	£6,395	£8,295
8	RÉGUA, PORTUGAL	Oct pricing per person from: with £1,000pp saving	£3,695	£5,695	£5,895	£6,295
9-10	PORTO, PORTUGAL	Nov pricing per person from: with £1,000pp saving	£3,495	£5,195	£5,395	£6,095
8-DAY CRUISE WITH RIVER-VIEW STATEROOM, PLUS 2-NIGHT LISBON HOTEL STAY						
One complimentary shore excursion in almost every port of call.						

Terms and conditions: Prices and availability are correct at the time of going to print but are subject to change. Prices are per person based on double occupancy and include an early booking discount of £1,000pp. From prices are based on the lowest stateroom grade available for each category. From prices are based on the lowest priced departure date within the month. Some departure dates within the same month may be at a higher cost. Gratuities included on board ship only. Single supplements: F-E 50%, D-AA 100%. Please see back page for full terms and conditions.

LEFT: VIKING LONGSHIP, PORTO AT SUNSET
RIGHT: TRADITIONAL PASTEL DE NATA



RHINE GETAWAY

Basel to Amsterdam | 8 days | Mar-Nov 2025 departures | From £1,795 per person

Explore one of Europe's best-loved rivers. Discover the turreted fortresses, grand cathedrals, historic cities, medieval towns and stunning scenery of the Middle Rhine—a UNESCO World Heritage Site. Taste the region's renowned white wines, the roots of its terraced vineyards reaching back to Roman times. Savour the various culinary traditions of Alsace. With calls in Amsterdam, Cologne and Basel, this journey reveals a rich landscape of beauty and culture.

DAY	DESTINATION	Viking Longships Mar–Nov 2025 departures	STANDARD	FRENCH BALCONY	VERANDA	VERANDA SUITE	EXPLORER SUITE		
1	BASEL, SWITZERLAND	Mar pricing per person from:		with £1,000pp saving	£1,895	£2,295	£2,595	£4,495	£5,295
2	BREISACH, GERMANY	Apr pricing per person from:		with £1,000pp saving	£2,295	£2,895	£3,295	£5,295	£6,895
3	STRASBOURG, FRANCE	May pricing per person from:		with £1,000pp saving	£2,695	£3,695	£4,095	£5,695	£7,295
4	SPEYER, GERMANY	Jun pricing per person from:		with £1,000pp saving	£2,595	£3,495	£3,795	£5,495	£7,095
5	KOBLENZ, GERMANY	Jul-Aug pricing per person from:		with £1,000pp saving	£2,295	£2,895	£3,295	£5,095	£6,295
6	COLOGNE, GERMANY	Sep pricing per person from:		with £1,000pp saving	£2,695	£3,695	£4,095	£5,695	£7,295
7	KINDERDIJK, THE NETHERLANDS	Oct pricing per person from:		with £1,000pp saving	£2,195	£2,995	£3,295	£4,795	£5,995
8	AMSTERDAM, THE NETHERLANDS	Nov pricing per person from:		with £1,000pp saving	£1,795	£2,295	£2,595	£4,295	£5,195

One complimentary shore excursion in almost every port of call.
This itinerary is also available in the reverse direction.

Terms and conditions: Prices and availability are correct at the time of going to print but are subject to change. Prices are per person based on double occupancy and include an early booking discount of £1,000pp. From prices are based on the lowest stateroom grade available for each category. From prices are based on the lowest priced departure date within the month. Some departure dates within the same month may be at a higher cost. Gratuities included on board ship only. Single supplements: F-E 50%, D-ES 100%. Please see back page for full terms and conditions.

LEFT: STRASBOURG, FRANCE
RIGHT: WINDMILLS IN KINDERDIJK, THE NETHERLANDS



DANUBE WALTZ

Budapest to Passau | 8 days | Mar-Nov 2025 departures | From £1,795 per person

Soak up soothing steam at a Budapest thermal bath. Learn to waltz at a Viennese dance school. Savour Austro-Hungarian cuisine in Vienna and Budapest. Admire the Wachau Valley's beauty. Explore lesser-known Central European cities like Bratislava and Passau. Witness daily monastic life on an exclusive visit to Göttweig Abbey. This eight-day itinerary reveals the best of these places while sailing leisurely through spectacular scenery.

DAY	DESTINATION	Viking Longships Mar–Nov 2025 departures	STANDARD	FRENCH BALCONY	VERANDA	VERANDA SUITE	EXPLORER SUITE
1-2	BUDAPEST, HUNGARY	Mar pricing per person from: with £1,000pp saving	£1,795	£2,295	£2,595	£3,595	£4,395
3	BRATISLAVA, SLOVAKIA	Apr pricing per person from: with £1,000pp saving	£1,995	£2,495	£2,895	£3,995	£4,795
4	VIENNA, AUSTRIA	May pricing per person from: with £1,000pp saving	£2,595	£3,495	£3,895	£5,595	£7,195
5	KREMS, AUSTRIA	Jun pricing per person from: with £1,000pp saving	£2,495	£3,295	£3,695	£5,495	£7,095
6	LINZ, AUSTRIA	Jul-Aug pricing per person from: with £1,000pp saving	£2,295	£2,995	£3,395	£5,195	£6,395
7-8	PASSAU, GERMANY	Sep pricing per person from: with £1,000pp saving	£2,695	£3,895	£4,295	£5,995	£7,595
		Oct pricing per person from: with £1,000pp saving	£2,095	£2,795	£3,195	£4,395	£5,195
		Nov pricing per person from: with £1,000pp saving	£1,795	£2,395	£2,795	£3,895	£4,795

One complimentary shore excursion in almost every port of call. This itinerary is also available in the reverse direction.

Terms and conditions: Prices and availability are correct at the time of going to print but are subject to change. Prices are per person based on double occupancy and include an early booking discount of £1,000pp. From prices are based on the lowest stateroom grade available for each category. From prices are based on the lowest priced departure date within the month. Some departure dates within the same month may be at a higher cost. Gratuities included on board ship only. Single supplements: F-E 50%, D-ES 100%. Please see back page for full terms and conditions.

LEFT: VIKING LONGSHIP SAILING THE DANUBE, BUDAPEST
RIGHT: HOFBURG, VIENNA



PASSAGE TO EASTERN EUROPE

Bucharest to Budapest | 11 days | Mar-Nov 2025 departures | From £2,895 per person

See Bucharest's 3,000-room Palace of Parliament. Make *banitsa* bread with a home cook in Vidin. Explore Belgrade's Ottoman and European treasures, including the 6th-century Kalemegdan Fortress. View the Danube's towering Iron Gate. Witness Hungary's daredevil Puszta horsemen. Behold Budapest's grandeur. Once hidden behind the Iron Curtain, the eastern Danube still has secrets to reveal on this enriching itinerary.

DAY	DESTINATION	Viking Longships Mar-Nov 2025 Departures	STANDARD	FRENCH BALCONY	VERANDA	VERANDA SUITE	EXPLORER SUITE
1-2	BUCHAREST, ROMANIA	Mar pricing per person from: with £1,000pp saving	£3,195	£3,595	£3,995	£6,495	£7,995
3	RUSE, BULGARIA	Apr pricing per person from: with £1,000pp saving	£3,495	£4,095	£4,495	£6,895	£8,395
4	VIDIN, BULGARIA	May pricing per person from: with £1,000pp saving	£3,895	£4,895	£5,195	£7,995	£9,595
5	SCENIC SAILING: THE IRON GATE	Jun pricing per person from: with £1,000pp saving	£3,695	£4,695	£5,095	£7,595	£9,195
6	BELGRADE, SERBIA	Jul-Aug pricing per person from: with £1,000pp saving	£3,195	£3,995	£4,395	£6,495	£7,995
7	OSIJEK, CROATIA	Sep pricing per person from: with £1,000pp saving	£3,895	£5,095	£5,495	£7,995	£9,595
8	KALOCSA, HUNGARY	Oct pricing per person from: with £1,000pp saving	£3,195	£3,995	£4,695	£6,495	£7,995
9-11	BUDAPEST, HUNGARY	Nov pricing per person from: with £1,000pp saving	£2,895	£3,895	£4,295	£6,095	£7,595

8-DAY CRUISE WITH RIVER-VIEW STATEROOM, PLUS 1-NIGHT BUCHAREST & 2-NIGHT BUDAPEST HOTEL STAY

One complimentary shore excursion in almost every port of call. This itinerary is also available in the reverse direction.

Terms and conditions: Prices and availability are correct at the time of going to print but are subject to change. Prices are per person based on double occupancy and include an early booking discount of £1,000pp. From prices are based on the lowest stateroom grade available for each category. From prices are based on the lowest priced departure date within the month. Some departure dates within the same month may be at a higher cost. Gratuities included on board ship only. Single supplements: F-E 50%, D-ES 100%. Please see back page for full terms and conditions.

LEFT: THE PALACE OF THE PARLIAMENT, BUCHAREST, ROMANIA
RIGHT: LIBERTY BRIDGE, BUDAPEST



LYON & PROVENCE

Avignon to Lyon | 8 days | Mar-Nov 2025 departures | From £2,295 per person

Tap into your inner Van Gogh at an Arles painting class. Discover Roman Provence at Les Arènes d'Arles and the Pont du Gard. Explore the world's largest Gothic palace at Avignon's grand Palace of the Popes. Excite your palate in Lyon, capital of French gastronomy. Savour local wines, hunt for truffles and see how *chèvre* cheese is made. Come witness the beauty that inspired artists like Cézanne and Chagall on this eight-day voyage along the Rhône.

DAY	DESTINATION	Viking Longships Mar-Nov 2025 departures	STANDARD	FRENCH BALCONY	VERANDA	VERANDA SUITE	EXPLORER SUITE
1	AVIGNON, FRANCE	Mar pricing per person from: with £1,000pp saving	£2,295	£2,995	£3,195	£4,895	£5,695
2	ARLES, FRANCE	Apr pricing per person from: with £1,000pp saving	£2,595	£3,695	£4,095	£6,495	£7,995
3	AVIGNON, FRANCE	May pricing per person from: with £1,000pp saving	£2,895	£4,095	£4,595	£7,295	£8,795
4	VIVIERS, FRANCE	Jun pricing per person from: with £1,000pp saving	£2,695	£3,795	£4,295	£6,895	£7,995
5	TOURNON, FRANCE	Jul-Aug pricing per person from: with £1,000pp saving	£2,495	£3,295	£3,695	£5,695	£7,295
6-8	LYON, FRANCE	Sep pricing per person from: with £1,000pp saving	£2,895	£4,095	£4,595	£7,295	£8,795
		Oct pricing per person from: with £1,000pp saving	£2,495	£3,295	£3,795	£5,695	£6,895
		Nov pricing per person from: with £1,000pp saving	£2,295	£2,895	£3,195	£4,895	£5,695

One complimentary shore excursion in almost every port of call. This itinerary is also available in the reverse direction.

Terms and conditions: Prices and availability are correct at the time of going to print but are subject to change. Prices are per person based on double occupancy and include an early booking discount of £1,000pp. From prices are based on the lowest stateroom grade available for each category. From prices are based on the lowest priced departure date within the month. Some departure dates within the same month may be at a higher cost. Gratuities included on board ship only. Single supplements: F-E 50%, D-ES 100%. Please see back page for full terms and conditions.

LEFT: LAVENDER FIELDS, PROVENCE
RIGHT: LYON, FRANCE



CHÂTEAUX, RIVERS & WINE

Bordeaux Roundtrip | 8 days | Mar-Nov 2025 departures | From £2,295 per person

Discover the ports, vineyards, farms and forests of Aquitaine, once Europe's richest kingdom. See Bordeaux's fountains and cellars. Hunt for truffles in Périgord, and create your own personal blend of Cognac at the Camus distillery. Savour France's finest oysters fresh from the bay at Arcachon. Sip Saint-Émilion, Médoc and Sauternes in their own "terroir" on an eight-day journey through Bordeaux—a region synonymous with fine wine and finer living.

DAY	DESTINATION	Viking Longships Mar–Nov 2025 departures	STANDARD	FRENCH BALCONY	VERANDA	VERANDA SUITE	EXPLORER SUITE
1-2	BORDEAUX, FRANCE	Mar pricing per person from: with £1,000pp saving	£2,295	£2,895	£3,495	£5,695	SOLD OUT
3	CADILLAC (SAUTERNES), FRANCE	Apr pricing per person from: with £1,000pp saving	£2,695	£3,495	£4,095	£6,495	£8,795
4	LIBOURNE, FRANCE	May pricing per person from: with £1,000pp saving	£2,895	£3,895	£4,495	£7,295	£9,595
5	BOURG, FRANCE	Jun pricing per person from: with £1,000pp saving	£2,695	£3,495	£4,095	£6,495	£8,795
6	MÉDOC & MARGAUX WINE COUNTRY, FRANCE	Jul-Aug pricing per person from: with £1,000pp saving	£2,495	£3,195	£3,595	£5,695	£7,995
7-8	BORDEAUX, FRANCE	Sep pricing per person from: with £1,000pp saving	£2,895	£3,895	£4,495	£6,695	£9,095
		Oct pricing per person from: with £1,000pp saving	£2,595	£3,295	£3,895	£6,095	£8,395
		Nov pricing per person from: with £1,000pp saving	£2,395	£3,095	£3,495	£5,695	£7,295

One complimentary shore excursion in almost every port of call.

Terms and conditions: Prices and availability are correct at the time of going to print but are subject to change. Prices are per person based on double occupancy and include an early booking discount of £1,000pp. From prices are based on the lowest stateroom grade available for each category. From prices are based on the lowest priced departure date within the month. Some departure dates within the same month may be at a higher cost. Gratuities included on board ship only. Single supplements: F-E 50%, D-ES 100%. Please see back page for full terms and conditions.

LEFT: BORDEAUX, FRANCE
RIGHT: VINEYARD



ELEGANT ELBE

Berlin to Prague | 10 days | Mar-Jul; Sep-Nov 2025 departures | From £2,795 per person

Discover Berlin’s modern chic, Potsdam’s rococo whimsy and Prague’s Gothic exuberance. Walk in Martin Luther’s footsteps in Wittenberg, birthplace of the Protestant Reformation. Admire delicate Meissen porcelain. Celebrate Dresden, a phoenix risen from the ashes of war. View Saxon Switzerland’s monoliths. See the Elbe Biosphere Reserve. The Elbe is one of Europe’s most unspoiled rivers and it awaits you — on our 10-day itinerary.

DAY	DESTINATION	Viking Longships - Elbe Mar-Jul; Sep-Nov 2025 Departures	STANDARD	FRENCH BALCONY	VERANDA	VERANDA SUITE
1-2	BERLIN, GERMANY	Mar pricing per person from: with £1,000pp saving	£2,995	£3,495	£3,895	£5,995
3	POTSDAM, GERMANY	Apr pricing per person from: with £1,000pp saving	£3,195	£3,895	£4,295	£6,395
4	WITTENBERG, GERMANY	May pricing per person from: with £1,000pp saving	£3,695	£4,795	£5,195	£7,595
5	MEISSEN, GERMANY	Jun pricing per person from: with £1,000pp saving	£3,395	£4,395	£4,795	£7,195
6	DRESDEN, GERMANY	Jul pricing per person from: with £1,000pp saving	£3,395	£3,995	£4,095	£6,795
7	SCENIC SAILING: SAXON SWITZERLAND	Sep pricing per person from: with £1,000pp saving	£3,795	£4,795	£5,195	SOLD OUT
8	DĚČÍN, CZECH REPUBLIC	Oct pricing per person from: with £1,000pp saving	£3,195	£3,895	£4,295	£6,395
9-10	PRAGUE, CZECH REPUBLIC	Nov pricing per person from: with £1,000pp saving	£2,795	£3,195	£3,595	£5,695

One complimentary shore excursion in almost every port of call. This itinerary is also available in the reverse direction.

Terms and conditions: Prices and availability are correct at the time of going to print but are subject to change. Prices are per person based on double occupancy and include an early booking discount of £1,000pp. From prices are based on the lowest stateroom grade available for each category. From prices are based on the lowest priced departure date within the month. Some departure dates within the same month may be at a higher cost. Gratuities included on board ship only. Single supplements: F-E 50%, D-AA 100%. Please see back page for full terms and conditions.

LEFT: VIKING LONGSHIP, MEISSEN, GERMANY
RIGHT: CHARLES BRIDGE, PRAGUE



CAPITALS OF EASTERN EUROPE

Vienna to Bucharest | 17 days | Mar-Nov 2025 departures | From £4,395 per person

Discover the “City of Waltzes”, Austria’s elegant capital and European centre of classical music. In Bratislava, view grand palaces from the Hapsburg era and delve into Budapest’s vibrant culture. Be captivated by lesser-known gems as you visit towns and cities across the Balkans. Explore Bucharest’s old-world charm, tree-lined boulevards and witness its socialist architecture. With visits to five capital cities, this 17-day voyage is sure to inspire.

DAY	DESTINATION	Viking Longships Mar-Nov 2025 Departures	STANDARD	FRENCH BALCONY	VERANDA	VERANDA SUITE	EXPLORER SUITE
1-3	VIENNA, AUSTRIA	Mar pricing per person from: with £1,000pp saving	£4,395	£6,395	£7,195	£10,495	£12,095
4	BRATISLAVA, SLOVAKIA	Apr pricing per person from: with £1,000pp saving	£4,495	£6,495	£7,295	£10,495	£12,095
5-6	BUDAPEST, HUNGARY	May pricing per person from: with £1,000pp saving	£4,895	£6,895	£7,695	SOLD OUT	£12,895
7	MOHÁCS, HUNGARY	Jun pricing per person from: with £1,000pp saving	£4,495	£6,495	£7,295	£10,495	SOLD OUT
8	VUKOVAR, CROATIA	Jul-Aug pricing per person from: with £1,000pp saving	£4,495	£6,495	£7,295	£10,495	£12,095
9	NOVI SAD, SERBIA	Sep pricing per person from: with £1,000pp saving	£4,895	£6,895	£7,695	£11,295	£12,895
10	BELGRADE, SERBIA	Oct pricing per person from: with £1,000pp saving	£4,495	£6,495	£7,295	£9,695	SOLD OUT
11	DONJI MILANOVAC, SERBIA	Nov pricing per person from: with £1,000pp saving	£4,395	£6,395	£7,195	£9,695	£11,295
12	VIDIN, BULGARIA						
13	PLEVEN, BULGARIA						
14	CONSTANȚA, ROMANIA						
15-17	BUCHAREST, ROMANIA						

One complimentary shore excursion in almost every port of call. This itinerary is also available in the reverse direction.

Terms and conditions: Prices and availability are correct at the time of going to print but are subject to change. Prices are per person based on double occupancy and include an early booking discount of £1,000pp. From prices are based on the lowest stateroom grade available for each category. From prices are based on the lowest priced departure date within the month. Some departure dates within the same month may be at a higher cost. Gratuities included on board ship only. Single supplements: F-E 50%, D-ES 100%. Please see back page for full terms and conditions.

LEFT: BRATISLAVA, SLOVAKIA
RIGHT: KARADORDE MONUMENT, BELGRADE, SERBIA



FRANCE'S FINEST

Paris to Avignon | 15 days | Mar-Nov 2025 departures | From £4,590 per person

Explore Avignon's Palace of the Popes and savour Lyon's culinary heritage. Toast centuries-old vineyards and luxuriate in Paris's sophistication. Walk in Joan of Arc's footsteps at Rouen. Pay your respects at Normandy's World War II beaches. Art, cuisine, style, *joie de vivre*—if you love everything *français*, this is for you: a 15-day journey that combines our popular *Lyon & Provence* and *Paris & the Heart of Normandy* itineraries into one tour de force.

DAY	DESTINATION	Viking Longships Mar-Nov 2025 Departures	STANDARD	FRENCH BALCONY	VERANDA	VERANDA SUITE	EXPLORER SUITE
1-2	PARIS, FRANCE	Mar pricing per person from: with £1,000pp saving	£4,890	£6,690	£7,490	£11,290	£14,090
3	LA ROCHE-GUYON, FRANCE	Apr pricing per person from: with £1,000pp saving	£5,490	£7,390	£8,490	£12,590	£16,290
4	SCENIC SAILING: SEINE RIVER	May pricing per person from: with £1,000pp saving	£6,090	£8,790	£9,890	£14,890	£18,790
5	NORMANDY BEACHES, FRANCE	Jun pricing per person from: with £1,000pp saving	£5,590	£7,790	£8,790	£13,390	£16,690
6	LES ANDELYS, FRANCE	Jul-Aug pricing per person from: with £1,000pp saving	£5,190	£7,090	£7,990	£11,590	£15,190
7	PARIS (LE PECQ), FRANCE	Sep pricing per person from: with £1,000pp saving	£6,090	£8,790	£9,890	£14,890	£18,790
8	PARIS, FRANCE	Oct pricing per person from: with £1,000pp saving	£4,990	£6,490	£7,290	£10,990	£13,690
9-10	LYON, FRANCE	Nov pricing per person from: with £1,000pp saving	£4,590	£6,090	£6,790	£9,190	£10,890
11	VIENNE, FRANCE						
12	TOURNON, FRANCE						
13	ARLES, FRANCE						
14-15	AVIGNON, FRANCE						

One complimentary shore excursion in almost every port of call. This itinerary is also available in the reverse direction.

Terms and conditions: Prices and availability are correct at the time of going to print but are subject to change. Prices are per person based on double occupancy and include an early booking discount of £1,000pp. From prices are based on the lowest stateroom grade available for each category. From prices are based on the lowest priced departure date within the month. Some departure dates within the same month may be at a higher cost. Gratuities included on board ship only. Single supplements: F-E 50%, D-ES 100%. Please see back page for full terms and conditions.

LEFT: EIFFEL TOWER, PARIS
RIGHT: PONT SAINT-BÉNÉZET, AVIGNON



TULIPS & WINDMILLS

Amsterdam Roundtrip | 10 days | Mar-Apr 2025 departures | From £2,495 per person

Admire the genius of the Dutch Masters at Amsterdam’s Rijksmuseum. Explore Hoorn’s seafaring heritage, Arnhem’s World War II history and Antwerp’s Renaissance splendour. See colourful tulips in bloom, and sample Belgian beers and chocolates. Step into the Middle Ages in Bruges. Roam Keukenhof Gardens, the world’s largest floral park. The best time to see the Low Countries is spring, and the best way to see them is on our 10-day itinerary.

DAY	DESTINATION	Viking Longships Mar-Apr 2025 Departures	STANDARD	FRENCH BALCONY	VERANDA	VERANDA SUITE	EXPLORER SUITE	
1-2	AMSTERDAM, THE NETHERLANDS	Mar pricing per person from:	with £1,000pp saving	£2,495	£3,295	£3,695	£4,895	£6,495
3	SCENIC SAILING: IJSSELMEER							
4	ARNHEM, THE NETHERLANDS	Apr pricing per person from:	with £1,000pp saving	£3,695	£4,495	£4,995	£6,995	£8,595
5	KINDERDIJK, THE NETHERLANDS	Terms and conditions: Prices and availability are correct at the time of going to print but are subject to change. Prices are per person based on double occupancy and include an early booking discount of £1,000pp. From prices are based on the lowest stateroom grade available for each category. From prices are based on the lowest priced departure date within the month. Some departure dates within the same month may be at a higher cost. Gratuities included on board ship only. Single supplements: F-E 50%, D-ES 100%. Please see back page for full terms and conditions.						
6	ANTWERP, BELGIUM							
7	MIDDELBURG, THE NETHERLANDS							
8	ZEELAND, THE NETHERLANDS							
9-10	AMSTERDAM, THE NETHERLANDS							

One complimentary shore excursion in almost every port of call.

LEFT: KINDERDIJK WINDMILLS, THE NETHERLANDS
RIGHT: CANAL, AMSTERDAM, THE NETHERLANDS



PHARAOS & PYRAMIDS

Cairo roundtrip | 12 days | Jan-Jun; Aug-Dec 2025 departures | From £6,495 per person

Uncover the ancient secrets of Egypt amid the welcoming culture of today. See the pyramids from astride a majestic camel. Explore the Temple of Karnak's 136 soaring pillars. Visit Queen Nefertari's tomb in the Valley of the Kings. Skim the waters of the Nile by traditional *felucca*. Enjoy the fragrances of Aswan's spice market. Join our expert Egyptologists on a 12-day itinerary through Egypt on board our modern Nile ships, owned and operated by Viking.

DAY	DESTINATION	Viking Longships - <i>Viking Aton</i> ; <i>Viking Hathor</i> ; <i>Viking Osiris</i> Jan-Jun; Aug-Dec 2025 Departures	STANDARD (B)	VERANDA (A)	VERANDA SUITE (AA)	EXPLORER SUITE (ES)
1-3	CAIRO, EGYPT	Jan pricing per person from:	£8,095	£9,295	£11,295	£13,695
4	LUXOR, EGYPT	Feb pricing per person from:	£8,095	£9,295	£11,295	SOLD OUT
5	QENA, EGYPT	Mar-Apr pricing per person from:	£7,695	£8,895	£10,895	SOLD OUT
6	LUXOR, EGYPT	May pricing per person from:	£7,295	£8,495	£10,495	£12,895
7	ESNA, EGYPT	Jun pricing per person from:	£6,895	£8,095	£10,095	£12,495
8-9	ASWAN, EGYPT	Aug pricing per person from:	£6,495	£7,695	£9,695	£12,095
10	EDFU, EGYPT	Sep pricing per person from:	£6,895	£8,095	£10,095	£12,495
11-12	CAIRO, EGYPT	Oct pricing per person from:	£7,295	£8,495	£10,495	£12,895
8-DAY CRUISE WITH RIVER-VIEW STATEROOM, PLUS 4-NIGHT CAIRO HOTEL STAY		Nov-Dec pricing per person from:	£7,295	£8,495	£10,495	£12,895

One complimentary shore excursion in almost every port of call.

Terms and conditions: Prices and availability are correct at the time of going to print but are subject to change. From prices are based on the lowest stateroom grade available for each category. From prices are based on the lowest priced departure date within the month. Some departure dates within the same month may be at a higher cost. Gratuities included on board ship only. Single supplements 100%. Please see back page for full terms and conditions.

IMPORTANT: VISA REQUIRED

Guests will require an Egyptian visa. This can be obtained on arrival into Egypt. This is not covered by Viking.

LEFT: GREAT PYRAMIDS OF GIZA
RIGHT: VIKING NILE SHIP, SAILING THROUGH EGYPT



MAGNIFICENT MEKONG

Hanoi to Ho Chi Minh City | 15 days | Jul-Dec 2025 departures | From £7,995 per person

Shop Old Hanoi's markets. See the Khmer temple complex of Angkor Wat. Behold the haunting beauty of Ta Prohm Temple, where jungle vines embrace ancient ruins. Explore Phnom Penh by cyclo rickshaw. Discover silk towns, fishing villages, monasteries and local river life. With hotel stays in Hanoi, Siem Reap and Ho Chi Minh City (Saigon) bracketing your eight-day Mekong voyage, this itinerary reveals the beauty and grace of a land we have only begun to know.

DAY	DESTINATION	Viking Longships Jul-Dec 2025 Departures	FRENCH BALCONY (C)	FRENCH BALCONY (C)	VERANDA (A)	EXPLORER SUITE (ES)
1-3	HANOI, VIETNAM	Jul pricing per person from:	SOLD OUT	£8,495	£8,995	£13,995
4-5	SIEM REAP, CAMBODIA	Aug pricing per person from:	£7,995	£8,495	£8,995	£13,995
6-7	KAMPONG CHAM, CAMBODIA	Sep pricing per person from:	£8,495	£8,995	£9,495	£14,995
8-9	PHNOM PENH, CAMBODIA	Oct pricing per person from:	£8,995	£9,495	£9,995	£15,495
10	SCENIC SAILING: MEKONG RIVER	Nov pricing per person from:	£8,995	£9,495	£9,995	£15,495
11	TÂN CHÂU, VIETNAM	Dec pricing per person from:	£8,495	£8,995	£9,495	£14,995
12	SA ĐÉC, VIETNAM					
13-15	HO CHI MINH CITY, VIETNAM					

**8-DAY CRUISE WITH RIVER-VIEW STATEROOM,
PLUS 2-NIGHT HO CHI MINH CITY; 3-NIGHT
SIEM REAP & 2-NIGHT HANOI HOTEL STAYS**

One complimentary shore excursion in almost every port of call.
This itinerary is also available in the reverse direction.

Terms and conditions: Prices and availability are correct at the time of going to print but are subject to change. From prices are based on the lowest stateroom grade available for each category. From prices are based on the lowest priced departure date within the month. Some departure dates within the same month may be at a higher cost. Gratuities included on board ship only. Single supplements 100%. Please see back page for full terms and conditions.

IMPORTANT: VISA REQUIRED

A visa is required for countries featured in this itinerary and must be arranged in advance of travel. Please note that the cost, process and countries that require a visa can change any time. The cost of the visa is additional and not covered by Viking.

LEFT: THE MEKONG RIVER
RIGHT: ANGKOR WAT, CAMBODIA



MISSISSIPPI EXPERIENCES

As one of the world's major river systems in size, biological activity and habitat diversity, we call it the "Mighty Mississippi" for good reason. And, a full sailing is a different kind of cross-country journey for the curious explorer — one that allows you to be immersed in American history and culture.

SOME OF THE MOST SCENIC STRETCHES of the Mississippi lie in the river's upper reaches, where the waterway is wide and clear, and where the landscape is diverse. Here you can admire the towering bluffs lining Minnesota, the rolling green farms of Wisconsin, the hills and caverns of Missouri, and amber waves of Iowa grain. The Upper Mississippi was once America's great frontier, a water boundary whose fertile banks supported Native Americans, westward pioneers, immigrant farmers, visionary entrepreneurs and many others. See the scenic landscape that served as the backdrop for trade and innovation for thousands of years.

THE TWISTS AND TURNS OF THE LOWER MISSISSIPPI seem to mirror the spirit of the South itself. Here, where the river snakes back on itself in fanciful spirals, you fall into a slower rhythm that is ideal for absorbing the region's lush beauty, captivating history, exquisite cuisine and easygoing hospitality. Experience the diversity of the South as you discover vibrant urban centres, historic battlefields, acclaimed museums, charming small towns and more. Here you will celebrate the literature, music, cuisine and hospitality of the varied peoples whose contributions have become part of America's national identity.



HEART OF THE DELTA

Prices from £5,595pp

NEW ORLEANS TO MEMPHIS

12 days, 10 guided tours

Departing Jan-Jun; Oct-Dec 2025

New Orleans • Darrow • Baton Rouge
• St. Francisville • Natchez • Vicksburg
• Greenville • Rosedale • Memphis



AMERICA'S HEARTLAND

Prices from £6,795pp

ST. LOUIS TO TWIN CITIES

12 days, 9 guided tours

Departing August 2025

• St. Louis • Hannibal • Burlington • Quad Cities
• Dubuque • La Crosse • Red Wing • Twin Cities

MORE ITINERARIES AVAILABLE - PLEASE VISIT RIVERCRUISING.CO.UK



Terms and conditions: Prices and availability are correct at time of going to print but are subject to change. From prices are based on two people sharing the lowest grade stateroom, departing on selected dates in 2025. Single supplements apply. Please see back page for more terms and conditions.

IMAGES TOP TO BOTTOM ON FACING PAGE: THE VIKING MISSISSIPPI, LOUISIANA; PENTHOUSE JUNIOR SUITE STATEROOM, THE VIKING MISSISSIPPI; LIVING ROOM, THE VIKING MISSISSIPPI; AQUAVIT TERRACE

VIKING LONGSHIPS

Viking Longships are the most award-winning class of river ships, having been recognised by Condé Nast Traveller, Travel + Leisure, Cruise Critic and more.

Built: 2012–2020 Length: 443 ft. Crew: 50 Guests: 190 Decks: 4
Staterooms: 95 (2 Explorer Suites, 7 Veranda Suites, 39 Veranda, 22 French Balcony, 25 Standard)

- Explorer Suite (ES)
- Veranda Suite (AA)
- Veranda (A)
- Veranda (B)
- French Balcony (C)
- French Balcony (D)
- Standard (E)
- Standard (F)

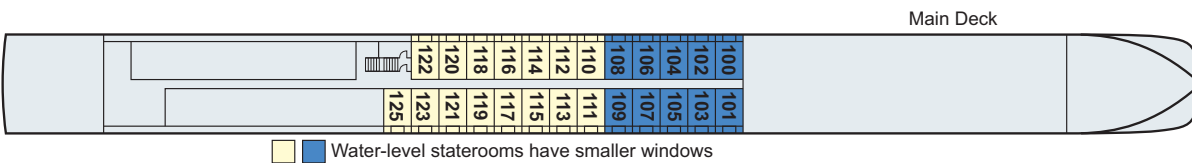
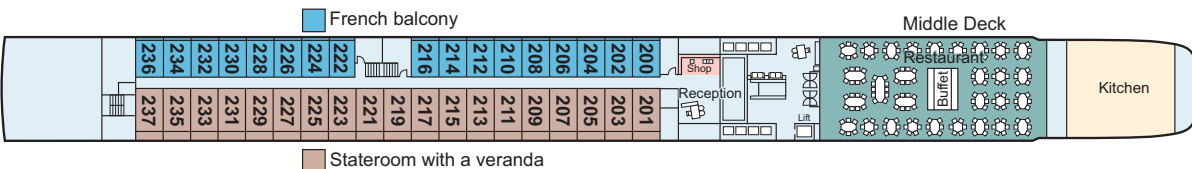
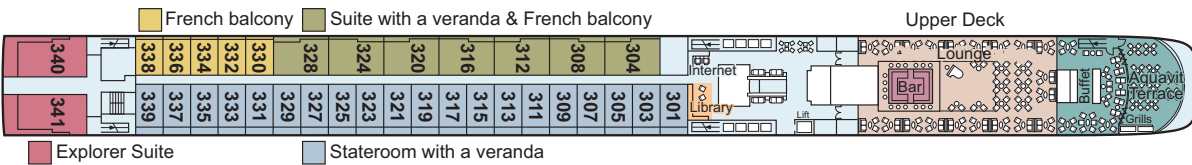
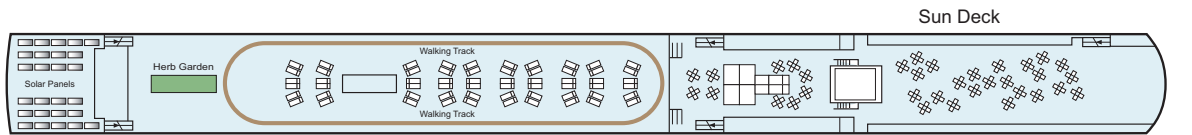
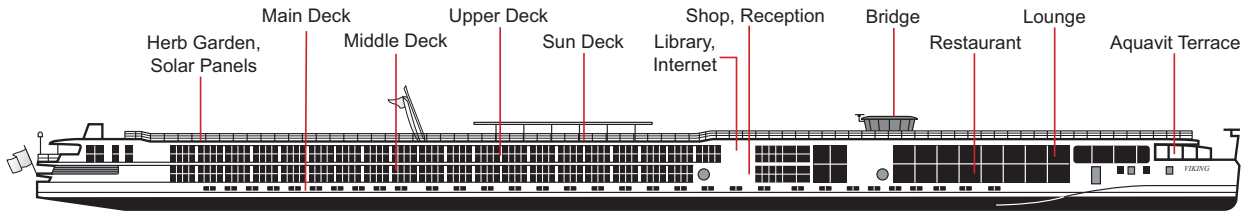

Water-level staterooms have smaller windows

- All staterooms are outside with river-view
- Lounge & bar with floor-to-ceiling glass doors that lead to an open air Aquavit Terrace
- Restaurant with floor-to-ceiling windows for panoramic views
- Sun Deck with shaded sitting area; organic herb garden & solar panels; and walking track
- Library & onboard boutique
- Lift, Middle to Upper Deck only
- Free Wi-Fi on board (connection speed may vary)
- Laundry service
- Bottled water replenished daily
- Voltage: 220V & 110V (US outlet) & USB ports in stateroom
- Ecologically friendly hybrid engines producing less vibrations for a smoother ride

OFFERING YOU A CHOICE OF STATEROOMS

LARGEST SUITES IN EUROPE



✦ One of two Explorer Suites

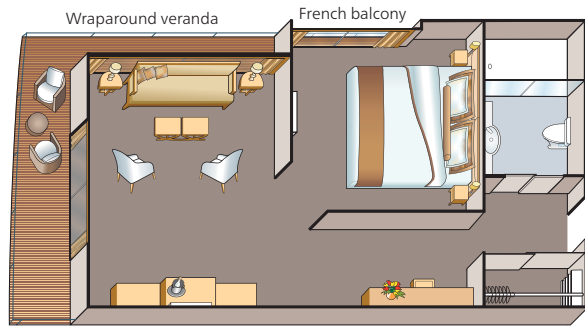

Explorer Suite (ES)
445 sq. ft.



✦ Veranda Suite

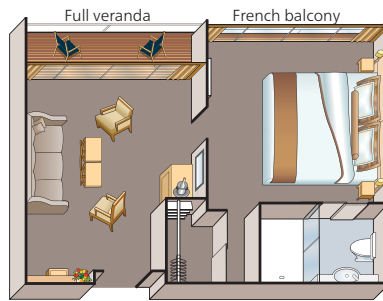

Veranda Suite (AA)
275 sq. ft.



✦ Veranda Stateroom

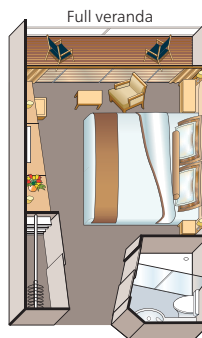

Veranda (A, B)
205 sq. ft.

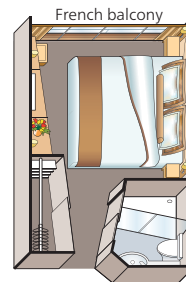

French Balcony (C, D)
135 sq. ft.

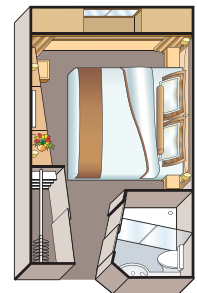

Standard (E, F)
150 sq. ft.

- Explorer Suites are 445 square feet, have separate sleeping & sitting quarters, a wraparound veranda with 270° views a French balcony & 2 flat-screen TVs
- Veranda Suites are 275 square feet, have separate sleeping & sitting quarters, a full veranda & French balcony & 2 flat-screen TVs

- All staterooms & suites have hotel-style beds with optional twin-bed configuration
- All Upper & Middle Deck staterooms have a full veranda or French balcony
- Private bathroom with shower; premium Freyja toiletries; robes & slippers

- 40" or 42" flat-screen Sony TV with infotainment system featuring Movies On Demand, plus CNBC, CNN, FOX, National Geographic and more
- Telephone, safe, refrigerator, hair dryer & individual climate control

Corridor configuration designs European Community Design #1832106-0001 to 1832106-0011.



VIKING LONGSHIPS - SEINE

These ships feature customised hulls and engines specifically built to navigate the historic Seine River.

Built: 2020 Length: 410 ft. Crew: 46 Guests: 168 Decks: 4
 Staterooms: 84 (2 Explorer Suites, 7 Veranda Suited, 35 Veranda, 18 French Balcony, 22 Standard)

- Explorer Suite (ES)
- Veranda Suite (AA)
- Veranda (A)
- Veranda (B)
- French Balcony (C)
- French Balcony (D)
- Standard (E)
- Standard (F)

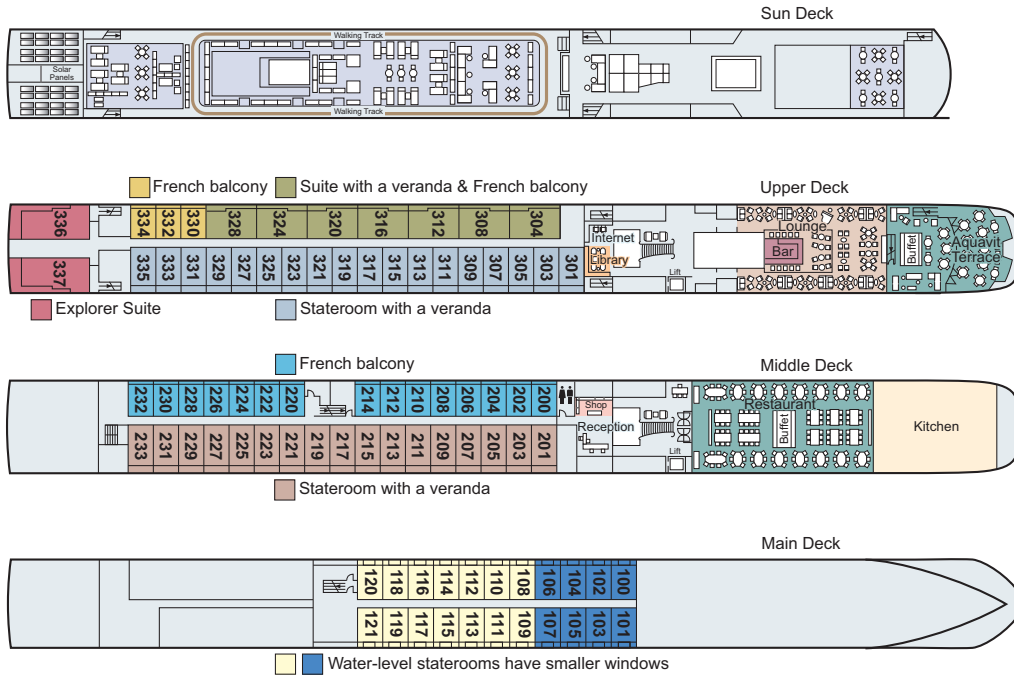

VIKING LONGSHIPS - ELBE

These beautiful ships are especially designed with a flat bottom to sail the more shallow River Elbe.

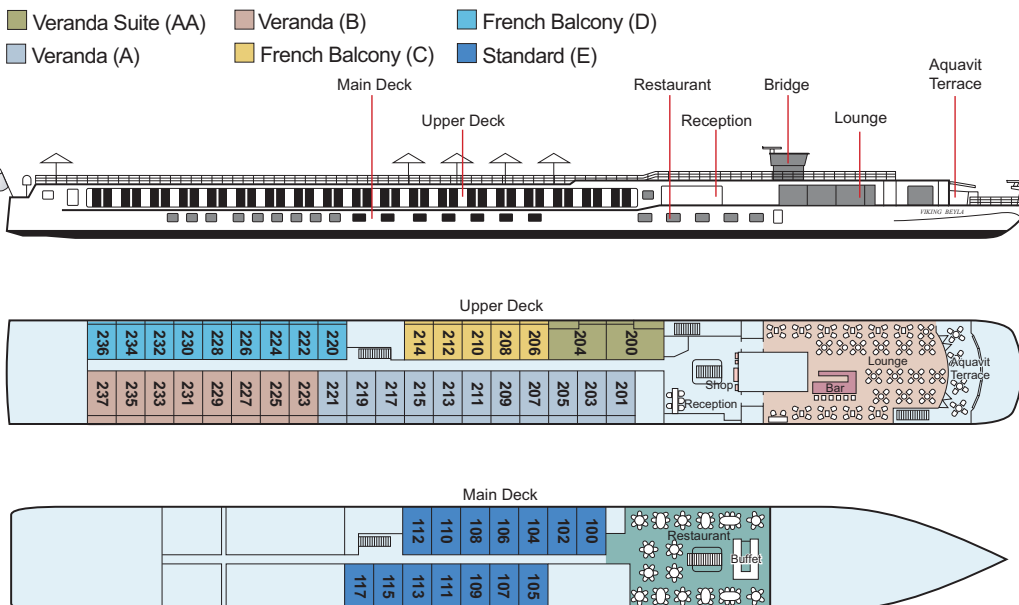



VIKING SAIGON

Designed to navigate the Mekong River, hosting just 80 guests, the Viking Saigon offers understated elegance and has been built to reflect the clean, Scandinavian design principles for which Viking is known.

■ Explorer Suite (ES) ■ Veranda (A) ■ French Balcony (B) ■ French Balcony (C)

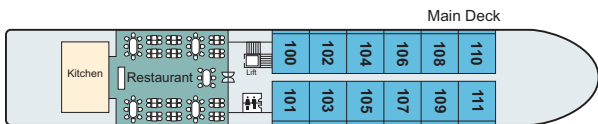
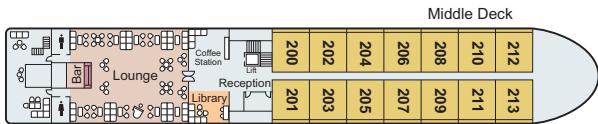
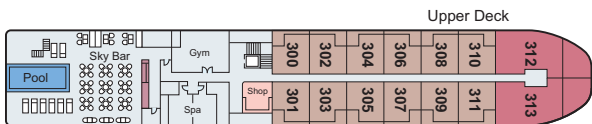
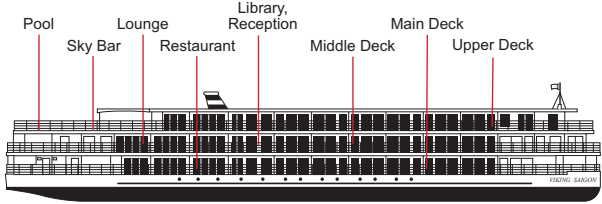

French Balcony (B, C)
305 sq. ft.

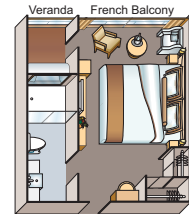

Veranda (A)
305 sq. ft.

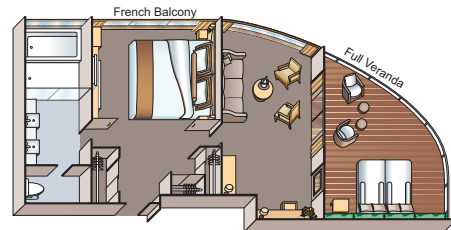

Explorer Suite (ES)
735 sq. ft.
with 170 sq. ft. Private Veranda

VIKING LONGSHIPS - DOURO

These vessels were exclusively built to sail Portugal's Douro River.

■ Suite (AB) ■ Veranda Suite (AA) ■ Veranda (A)
 ■ Veranda (B) ■ French Balcony (C) ■ French Balcony (D)
 ■ Standard (E) ■ Standard (F)

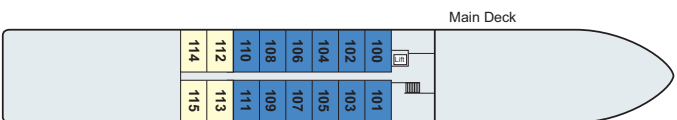
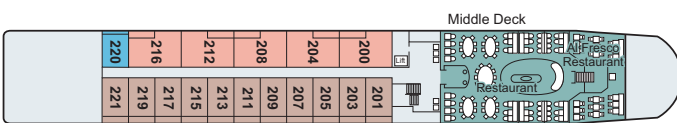
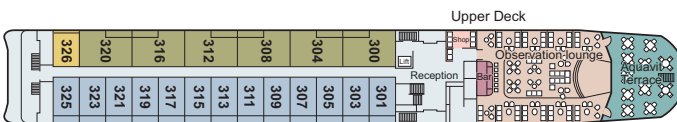
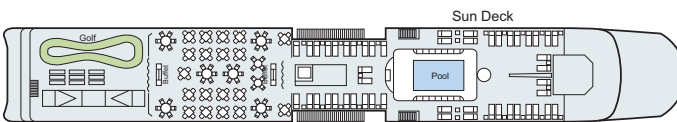

French balcony

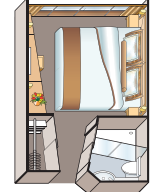

French Balcony (C, D)
150 sq. ft.

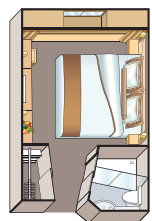

Standard (E, F)
155 sq. ft.

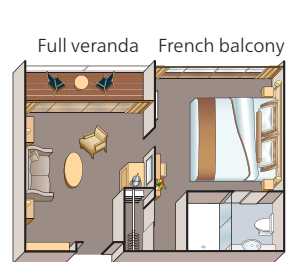

Veranda Suite (AA, AB)
302 sq. ft.

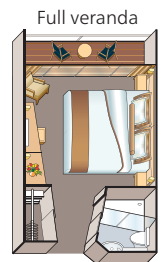

Veranda (A, B)
185 sq. ft.



VIKING MISSISSIPPI

Hosting 386 guests in 193 all outside staterooms, the new state-of-the-art the Viking Mississippi is inspired by our award-winning Viking Longships® and ocean ships and will feature clean Scandinavian design, as well as public spaces that are familiar to guests but that have been reimagined for Mississippi River voyages.

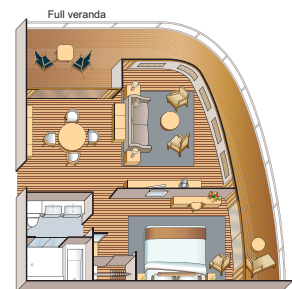
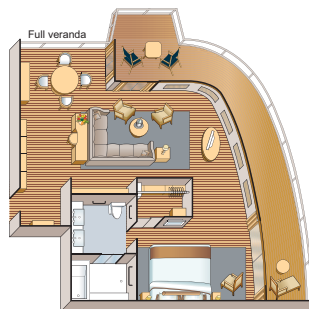
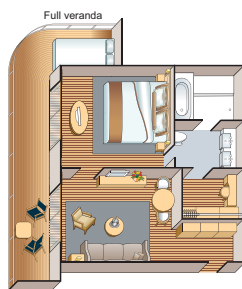
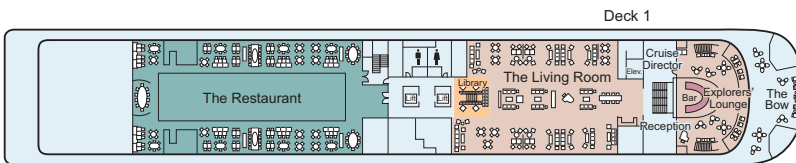
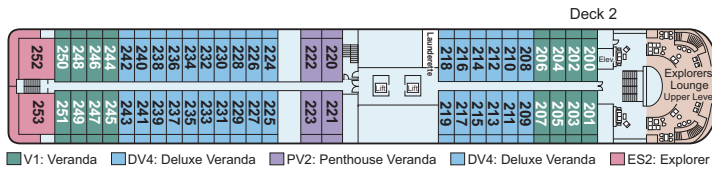
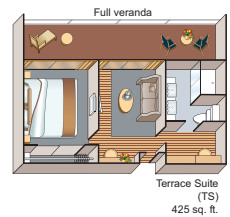
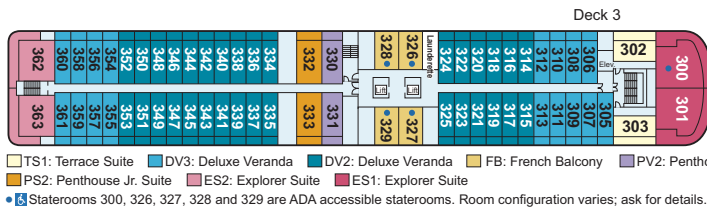
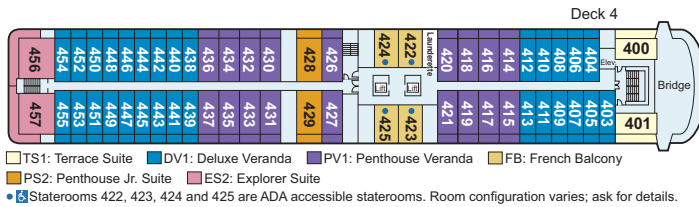
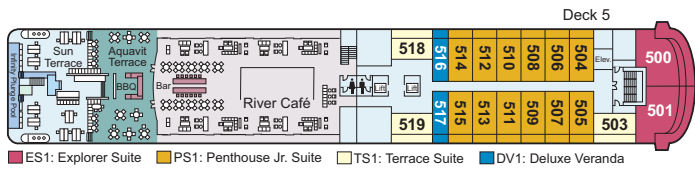
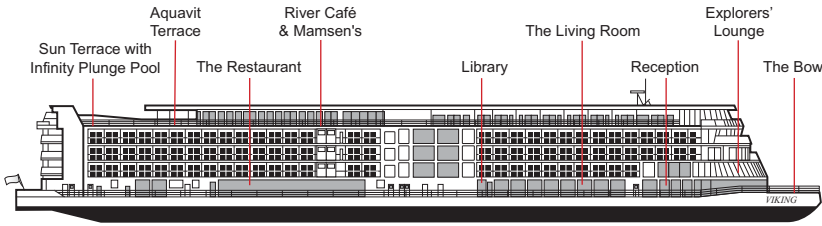



VIKING OSIRIS, VIKING ATON, VIKING HATHOR

The Viking Osiris, the Viking Aton and the Viking Hathor are brand new vessels, the most upscale ships in Egypt. They are state-of-the-art vessels - designed in the clean, elegant Scandinavian aesthetic for which Viking is known.

Veranda (A) Standard (B) Explorer Suite (ES) Suite (AA)

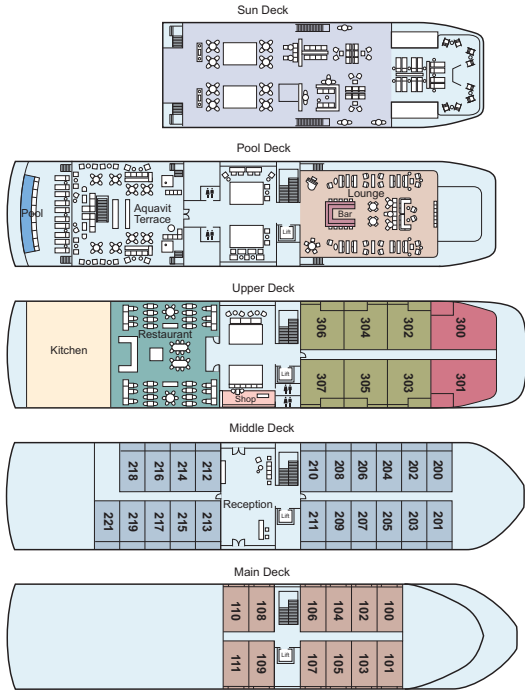

- 41 comfortable outside staterooms (12 Standard Staterooms, 21 Veranda Staterooms, 6 Veranda Suites, 2 Explorer Suites)
- Explorer suites feature two full-size rooms with a veranda off the bedroom & a spacious bathroom with separate bathtub and glass enclosed shower
- Veranda suites feature two full-size rooms with a veranda off the living room & a French balcony in the bedroom
- Pool & Sun Deck with 360-degree views & shaded sitting area
- Aquavit Terrace & Lounge, a revolutionary indoor/outdoor viewing area for *al fresco* dining
- Viking Lounge & Bar with floor-to-ceiling glass doors
- Restaurant with floor-to-ceiling windows for panoramic views
- Library & onboard shop
- Lift from Main Deck to Pool Deck only; no Lift access for Sun Deck
- Free Wi-Fi on board (connection speed may vary)
- Laundry service



Veranda (A)
239 sq. ft.

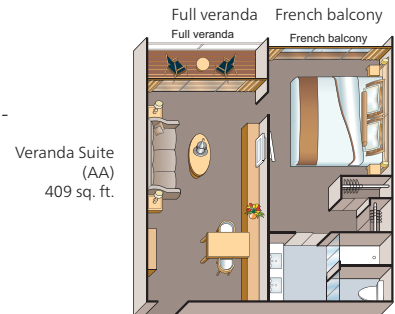

Veranda Suite (AA)
409 sq. ft.

VIKING RA

An all-suite vessel launched in 2018, the Viking Ra specifically built to navigate the Nile.

(AA) Veranda Suite (AB) Veranda Suite (AC) Suite

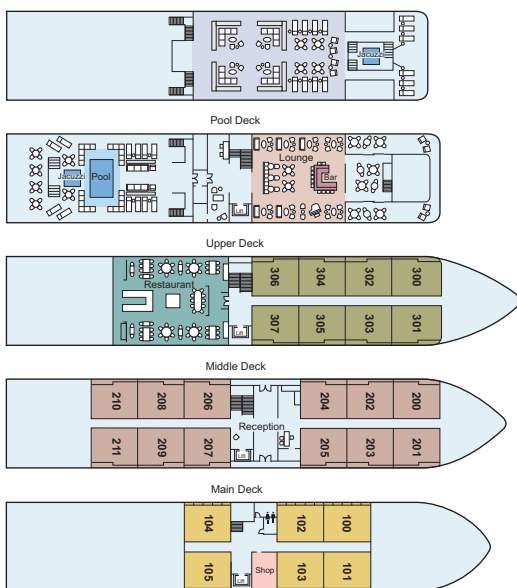

- All-suite state-of-the-art ship for just 52 guests
- Veranda Suites are 291 sq ft, featuring two rooms with a veranda off the living room and a French balcony in the bedroom, and have two flat-panel TVs
- Suites are 291 sq ft, featuring two rooms—each with a large picture window, and have two flat-panel TVs
- All suites have hotel-style beds with optional twin-bed configuration
- Sun Deck with 360-degree views and shaded sitting areas
- Pool and two Jacuzzis
- The Lounge and bar with floor-to-ceiling windows
- Restaurant with floor-to-ceiling windows for panoramic views
- Free Wi-Fi on board (connection speed may vary)
- Laundry service



Pictured: Veranda Suite



Veranda Suite (AA, AB)
291 sq. ft.





OCEAN JOURNEYS

SCANDINAVIA & NORTHERN EUROPE

MEDITERRANEAN

THE AMERICAS & CARIBBEAN

ASIA & AUSTRALIA

Experience the world in depth, and at a relaxed pace. The small size of our elegant, 930-passenger ships gives you access to fascinating ports that larger ships simply cannot reach. Our ocean traverse six continents and offer enriching cultural experiences.



VIKING OCEAN SHIPS

Reinventing Ocean Voyages

GUESTS: 930 LENGTH: 745 FT. BEAM: 94.5 FT. CLASS: SMALL SHIP

Environmentally Considerate

Designed to minimise pollution with energy efficient engines that meet stringent emission standards.

Al Fresco Dining

Viking ocean ships feature more options for dining outdoors than any other ship at sea.

World Café

With live cooking, an open kitchen, premium sushi and seafood choices, the World Café provides a wide range of international flavours.

Infinity Pool

The glass-backed Infinity Pool is cantilevered off the stern, allowing you to swim surrounded by your destination.

Wintergarden

Take afternoon tea in the serene Wintergarden, a stunning space under a canopy of trellised wood inspired by Yggdrasil, the "Tree of Life" in Norse mythology.

Main Pool with Retractable Dome

The heated Main Pool and hot tub provide a calming oasis in any weather; for a relaxed lunch or afternoon snack, the Pool Grill serves casual fare prepared to order.

Complimentary Wi-Fi

Stay connected with the world around you.



The Restaurant

The main dining room features daily-changing menus, including regional specialities made with fresh, local ingredients.

Alternative Restaurants

Choose from Manfredi's® Italian Restaurant, The Chef's Table, two private dining rooms or The Kitchen Table.

The Viking Living Room & the Atrium

Located in the heart of the ship, this space is ideal to relax with an afternoon coffee or pre-dinner cocktail, while enjoying live music performances.

Viking Heritage

The Vikings' rich history and inspiring legacy are displayed in our special onboard exhibit.

Promenade Deck

Designed in classic ocean liner style, this is the perfect place for walking or jogging on our ¼-mile continuous loop track.

Torshavn®

This cabaret lounge is ideal for an after-dinner drink.

The Nordic Shop

Browse our collection of Scandinavian clothing and handicrafts.

Underwater Stabilisers

Ensure smooth sailing regardless of weather.

Classified by Cruise Critic as “small ships”, our fleet of identical, all-veranda sister ships features understated elegance and modern Scandinavian design.

All Veranda Staterooms

Choose from five categories of spacious rooms, all with king-size beds, large showers, heated bathroom floors, LCD TVs, private verandas and 24-hour room service.

Sports Deck

Here you will find a walking track, golf putting green and bocce ball, along with plenty of seating to relax and enjoy the fresh air and spectacular views.

Explorers' Lounge

With two-storey panoramic windows for maximum views, this is the perfect place to relax and take in the scenery.

Paps, the Explorers' Bar

Enjoy a cocktail and mingle with fellow travellers in this bar with the best views at sea.

Mamsen's®

Serving traditional Norwegian snacks and light fare, early morning to late night.

Explorer Suites

In premium locations with wraparound verandas, these two-room suites offer maximum views.

Hair Salon

Treat yourself to an array of hair, nail and other salon services for men and women.

Fitness Centre

The best health club at sea features cardio machines, weights, an open space for yoga and Pilates and guided sessions with personal trainers.

Onboard Shops

A variety of onboard shops have everything you need to make your voyage comfortable and convenient.

The Theatre

Featuring comfortable seating, The Theatre and its two adjoining Cinemas are the perfect venues for lectures, Destination Performances and movies.

The Nordic Spa

Designed around the holistic wellness philosophy of Nordic culture, enjoy a traditional bathing ritual with the Sauna and Snow Grotto—or unwind with a facial or massage.

Yacht-Style Bow

An optimised hull for maximum fuel economy, speed and smooth sailing.







VIKING OCEAN SHIP INTERIORS

OUR OCEAN FLEET

WHEN WE SET OUT TO REINVENT OCEAN VOYAGES, we designed our ships from the inside out with your comfort in mind. With no casinos and no children under 18, the environment on board is quiet and calm. Open, light-filled public spaces serve as the perfect backdrop for reading, enjoying local musicians and visiting with fellow travellers.

PERUSE CLASSIC AND CONTEMPORARY PAINTINGS, sculptures and photographs by esteemed Scandinavian artists. See one of the largest collections of works by master expressionist Edvard Munch outside of Oslo's Munch Museum. Each of our ships features a distinct selection of Nordic art, and our Viking Art Guide app enhances your experience further with insightful commentary about the collection on board. In our well-curated library books throughout the ship, select from a broad range of titles from history and architecture to contemporary fiction and exploration.

OFFERING YOU A CHOICE OF STATEROOMS

Owner's Suite (OS) | Stateroom size: 1,448 sq ft

An expansive home away from home, the Owner's Suite pampers guests with the most exclusive accommodations and amenities on board. This multi-room suite features a separate seating area, dining room and boardroom plus a private library, wine and music collections curated by Chairman Torstein Hagen.



OWNER'S SUITE

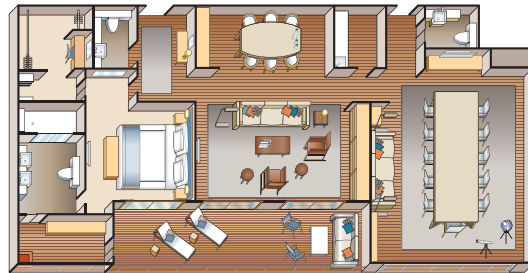

Explorer Suite (ES) | Stateroom size: 757–1,163 sq ft **A TRUE (TWO-ROOM) SUITE**

Ocean-view, two-room suite with floor-to-ceiling sliding glass door opening to a generous veranda. Spacious, well-appointed living and dining area with separate sleeping quarters.



EXPLORER SUITE

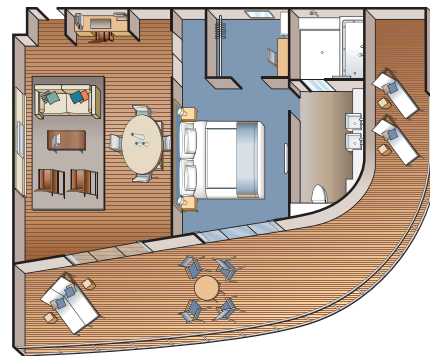

Penthouse Junior Suite (PS) | Stateroom size: 405 sq ft

Ocean-view suite with floor-to-ceiling sliding glass door opening to full-size veranda.



PENTHOUSE JR. SUITE

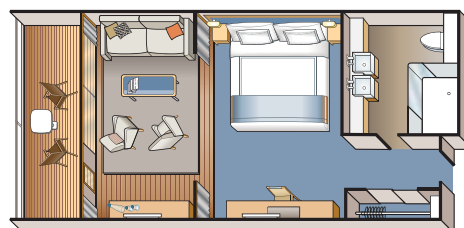

Penthouse Veranda Stateroom (PV) | Stateroom size: 338 sq ft

Ocean-view stateroom with floor-to-ceiling sliding glass door opening to full-size veranda. 25% larger than Veranda and Deluxe Veranda staterooms with more storage space.



PENTHOUSE VERANDA

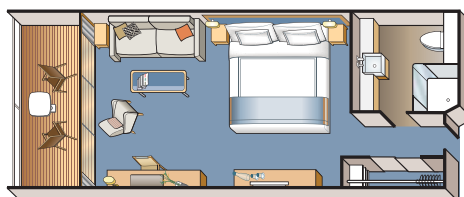

Deluxe Veranda Stateroom (DV) | Stateroom size: 270 sq ft

Ocean-view stateroom with floor-to-ceiling sliding glass door opening to full-size veranda.



DELUXE VERANDA STATEROOM

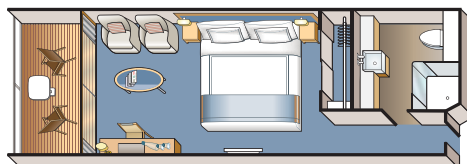

Veranda Stateroom (V) | Stateroom size: 270 sq ft

Ocean-view stateroom with floor-to-ceiling sliding glass door opening to full-size veranda.



VERANDA STATEROOM

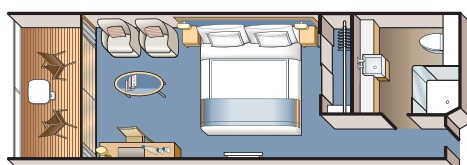



THE WINTERGARDEN

SAIL IN SCANDINAVIAN STYLE

Every room is a living room

THOUGHTFUL DETAILS that celebrate our Nordic heritage are chosen specifically with comfort in mind: clean lines, colourful woven textiles and light woods evoke the original Viking explorers' connection to the natural world.

PUBLIC SPACES LIKE THE WINTERGARDEN AND LANAI are light-filled, airy and quiet. Our more observant guests will also notice subtle tributes to Norse mythology incorporated into the design details. In the Explorers' Lounge, lit constellation maps and curated bookshelves are inspired by the world's greatest explorers. An ideal spot to linger over a glass of wine with fellow travellers, enjoy comfortable seating and sweeping views from floor-to-ceiling windows. Or, in Mamsen's Norwegian Deli, sample recipes of the Hagen family matriarch, for whom Mamsen's is named.



THE NORDIC SPA

SERENITY AT SEA

Designed with Nordic wellness in mind

OUR SPA EXPERIENCE draws upon the holistic wellness philosophy of Nordic culture, with treatments that include a variety of massages, facials and wraps.

IN THE THERMAL SUITE, to which all guests receive complimentary access, enjoy the ultimate Scandinavian tradition – relax in the Sauna and Steam Room; then invigorate yourself with a cold bucket shower or visit to the Snow Grotto. Afterward, complete your bathing ritual by soaking in the warm pool or resting in a heated lounge chair.

SHOULD YOU WISH TO EXERCISE, our state-of-the-art Fitness Centre is adjacent to the Nordic Spa. Or, visit our Hair Salon, where you can indulge with an array of hair, nail and grooming services – including our soothing Royal Nordic Hair ritual.



VIKING OCEAN SHIP, CROATIA

PURPOSE-BUILT SHIPS

Ocean vessels that bring you closer to your destination

At Viking, we build innovative ships that are the right size for the experience—with a signature Scandinavian design that never upstages the destination.

IDENTICAL ALL-VERANDA OCEAN SHIPS that host just 930 guests, with the ability to dock in the world's greatest cities, as well as seldom visited small ports that are out of reach for mega-liners.

SPEND MORE TIME IN PORT, with overnight stays in many ports of embarkation and disembarkation. With fewer days at sea, you will have ample time to immerse yourself in each destination.

TAKE IN YOUR SURROUNDINGS. With a private veranda in every stateroom, an Infinity Pool at the stern and abundant options for *al fresco* dining, each day brings new opportunities for stunning views of your destination.



SCANDINAVIAN DESIGN DETAILS ON BOARD VIKING SHIPS

UNDERSTATED ELEGANCE

Modern ships designed for comfort and discovery

Created by interior architects who have designed some of the world's finest hotels, the signature Scandinavian design of our ships celebrates our Nordic heritage: clean lines, colourful woven textiles and light woods that evoke the original Viking explorers' connection to the natural world. Public spaces are light-filled, airy and quiet; staterooms feature thoughtful amenities, including heated bathroom floors, anti-fog mirrors and luxury bed linens; and throughout each ship you will find great attention to detail in leather handrails, original Nordic artwork and libraries stocked with books curated by London bookshop Heywood Hill.



WARM, FRIENDLY STAFF

OUR VIKING FAMILY

Thoughtful attention from dedicated staff

ONLY THE VERY BEST. Our knowledgeable and highly experienced Swiss management oversees your entire journey and handpicks each member of our onboard team. Rigorous training and inspiring leadership have also made Viking the employer of choice.

A WARM WELCOME. We are dedicated to ensuring everyone feels at home on board our ships. We have the most loyal staff in the industry — with more than 90% returning year after year — so you can expect familiar faces and the same quality service every time you travel with us.



DESTINATION INSPIRED CUISINE, SALMON DÉCLINAISON

THE FLAVOURS OF YOUR DESTINATION

Experiencing a culture through its food and wine

A GREAT JOY OF TRAVEL lies in sampling the fresh fare and culinary traditions for which a place is known. Locally sourced ingredients — such as Norwegian salmon, Dutch Gouda and Spanish *jamón* — inspire our highly trained chefs to create authentic regional dishes on every itinerary. And our thoughtful wine list enhances your meal, with handpicked selections and onboard tastings that showcase an area's quintessential varietals.

DINING ON A VIKING SHIP, you will find the ideal setting for impeccable service and casual elegance. On our ocean ships, experience multiple dining options, from Mamsen's Norwegian Deli and the open kitchens of the World Café — to Manfredi's Italian trattoria and 24-hour room service. Across our fleet, we offer the most *al fresco* dining on any waterway, so you always have the option to enjoy a meal or a glass of wine while completely surrounded by the scenery.

THE BEST DINING CHOICES AT SEA

Choose from eight dining options, all with no additional charge



THE RESTAURANT

Our main dining venue, The Restaurant offers the highest onboard dining experience. Regional cuisine and always available classics are served surrounded by sweeping exterior views through all-glass walls.



MANFREDI'S

Inspired by Italy's beloved trattorias, Manfredi's offers the best of Italian cuisine with a private dining room providing an opportunity to have an intimate meal with family or friends.



THE CHEF'S TABLE

The sommeliers and culinary masters at The Chef's Table create the perfect food and wine pairings during a multicourse tasting, enjoyed in the restaurant or in a private dining room.



WORLD CAFÉ & AQUAVIT TERRACE

With live cooking, an open kitchen and premium sushi/seafood choices, the casual World Café and Aquavit Terrace provide a vibrant interactive experience and a wide range of international flavours in an *al fresco* setting.



MAMSEN'S NORWEGIAN DELI

Named for "Mamsen", the Hagen family matriarch, this venue offers Norwegian specialities including waffles according to Mamsen's recipe, open-faced sandwiches and split pea soup.



WINTERGARDEN

Afternoon tea — the hallmark of English civility — is served in the Wintergarden. Guests can participate in afternoon tea service accompanied by freshly made finger sandwiches, scones and desserts.



POOL GRILL

In a poolside atmosphere that welcomes lounging and leisurely dips in the water, the Pool Grill offers casual fare prepared to order. For a lighter meal, a small salad bar is available.



24-HOUR ROOM SERVICE

Guests can enjoy many of our signature dishes in the comfort of their stateroom, including the Chairman's favourite Norwegian poached salmon with cucumber salad.



VIKING RESIDENT MUSICIANS

ONBOARD ENRICHMENT

Bringing culture and history to life

VIKING RESIDENT HISTORIANS®

deliver high-level historic and cultural education specific to the itinerary, offering invaluable insight into the rich history of the destination.

GUEST LECTURERS expertly shed light on your destination's history, art, architecture and more.

PORT TALKS provide an overview of the next day's port of call through informative multimedia presentations.

DESTINATION PERFORMANCES showcase the most iconic cultural performing arts of the region.

COOKING DEMONSTRATIONS present recipes of regional treats and drinks.

CRAFT DEMONSTRATIONS

reveal centuries-old traditions of local artisans.

WINE TASTINGS introduce you to a wide selection of regional varietals or vintages.

VIKING RESIDENT MUSICIANS include a pianist, guitarist, violinist and cellist who perform calming classical compositions throughout the ship.

MUNCH MOMENTS showcase the artwork of Norway's iconic expressionist Edvard Munch during this daily onboard event.

THE KITCHEN TABLE lets you experience how our chefs bring local flavours from market to table.



ENRICHING EXCURSIONS

ONSHORE EXPERIENCES

Designed to take you closer, The Viking Way[®]

THE VIKING WAY OF EXPLORATION offers behind-the-scenes insights and opportunities that set us apart from other travel companies. While we feature the expected and iconic — such as visits to renowned museums and notable landmarks — we also offer our guests **LOCAL LIFE**, **WORKING WORLD** and **PRIVILEGED ACCESS[®]** experiences, opening doors to places otherwise difficult to visit.

Karine Hagen, Executive Vice President of Viking, has travelled the globe to develop these Viking Way experiences—and has captured some of them in a series of Destination Insights videos, which are available on our website, as well as our award-winning enrichment channel, **Viking.TV**. In addition to daily livestreams and hundreds of archived video sessions, guests have access to an extensive library of content to inform them about their upcoming journey and encourage deeper engagement while travelling.

VIKING INCLUSIVE VALUE

Pricing that covers everything you need—and nothing you do not

At Viking, we firmly believe that you should not have to incur an expense every time you want a cup of coffee, a glass of wine or an excursion ashore. Instead, our goal is to provide you with great value, so we have designed our voyages to give you more for your money with a fare that includes:

- Return economy scheduled flights from London and up to 10 regional airports
- One shore excursion in almost every port of call, led by a knowledgeable local guide
- Free Wi-Fi on board (connection speed may vary)
- All onboard meals featuring regional specialities & always available classics
- Alternative restaurant dining at no extra charge
- Beer, wine & soft drinks with onboard lunch & dinner
- 24-hour specialty coffees & teas
- Visits to UNESCO World Heritage Sites
- Enrichment lectures & destination performances
- Overseas ground transfers
- Complimentary access to The Nordic Spa & Fitness Centre
- 24-hour room service
- Self-service laundrettes
- Onboard gratuities
- Viking is a member of ABTA and is ATOL licensed

Plus, additional tools and services available to assist with travel planning include:

- Online booking to price & build your voyage in just a few steps
- **MY VIKING JOURNEY** online guest portal to select shore excursions, make dining reservations and personalise your voyage in advance of travel



ENVIRONMENTALLY CONSIDERATE

Reducing impact through design & technology

ALL VIKING OCEAN SHIPS come with the best Energy Efficiency Design Index (EEDI)* rating of their class, and they exceed the 2025 International Maritime Organisation (IMO)'s requirements by almost 20%. Key features of the ships' energy-efficient design include:

- **SLEEK HULL DESIGN.** From the bulbous bow to the "duck tail" platform at the stern, our ocean vessels have been designed with energy-efficient hulls, propellers and rudder arrangements to reduce resistance in the water and therefore reduce fuel consumption.
- **EFFICIENT USE OF SPACE.** On a ship, every bit of added weight results in extra fuel consumption. This is why we are careful to add only what is needed to our ships, prioritising optimal guest comfort and operational efficiency.
- **WASTE HEAT RECOVERY.** This process works by recovering heat from the engines and utilising it as a free source of energy for heating water, thereby saving fuel.
- **INTELLIGENT HVAC SYSTEM.** An automatic "Eco-mode" reduces power consumption when public areas and staterooms are not in use. Plus, water condensation created from the ship's HVAC system is reclaimed and used in the main laundry, further reducing the need for fresh water from external sources.
- **SHORE POWER.** Our newest ocean ships utilise shore power where possible to reduce reliance on fuel while in port. This feature is already providing a reduction in CO₂ emissions of up to 30% on some itinerary sections.
- **LED LIGHTING.** The lighting instruments on board are more energy-efficient LEDs, utilising low wattage and therefore lower heat output, lower power usage and a longer life.

*Since January 1, 2013, the Energy Efficiency Design Index (EEDI) was made mandatory for new ships, requiring a minimum energy efficiency level per capacity mile. This was the first legally binding climate change treaty to be adopted since the Kyoto Protocol.



FLÅM, NORWAY

Beyond the technical aspects of the ships' design, Viking ocean ships are also equipped with the following features to reduce environmental impact:

- **ADVANCED RECYCLING & WASTE MANAGEMENT.** Our entire fleet is equipped with advanced wastewater and ballast water treatment systems, as well as onboard waste/rubbish and recycling separation facilities to minimise the generation of waste and enable environmentally responsible recycling in shore facilities.
- **LIGHT REDUCTION.** We operate our vessels in a manner that minimises light pollution, reducing our impact on local communities and landscapes.
- **NOISE REDUCTION TECHNOLOGY.** With no children and no casinos, the environment on board our ships are quiet and calm. Furthermore, we have technology in place to reduce potential noise pollution in the destinations where we sail.
- **EXHAUST CLEANING SYSTEMS.** Our ocean ships were the first newbuilds in the world to be equipped with a closed-loop exhaust cleaning system designed so that pollutants can be stored on board and disposed of at suitable reception facilities ashore. Our newest ocean ships are also equipped with Selective Catalytic Reduction systems to virtually eliminate nitrogen oxides (NOx).

THE WORLD OF VIKING

Ocean Destinations

With an award-winning fleet of identical small ships, we have reinvented ocean voyages with thoughtful journeys designed to bring you to the heart of great destinations around the world.





Polar Ice Cap

Alaska USA

Seward

Valdez

Kodiak

Dutch Harbor

Skagway

Icy Strait Point

Juneau

Sitka

Ketchikan

Inside Passage

Victoria

Vancouver

Astoria

San Francisco

Santa Barbara

Los Angeles

San Diego

Cabo San Lucas

Nawiliwili

Honolulu USA

Pacific Ocean

CANADA

USA

MEXICO

Ft. Lauderdale

Cozumel

Belize City

Roatán

León

Puntarenas

Puerto Limón

COSTA RICA

Montego Bay

JAMAICA

Panama Canal

Panama City

Colón

PANAMA

Cartagena

COLOMBIA

îles du Salut

FRENCH GUIANA

Parintins

Manaus

Santarém

AMAZON RIVER

Brazil

Recife

Rio de Janeiro

URUGUAY

Santiago

Buenos Aires

Montevideo

CHILE

ARGENTINA

Puerto Montt

Puerto Madryn

Chilean Fjords

Punta Arenas

Ushuaia

Beagle Channel

Cape Horn

Port Stanley

Falkland Islands

GREENLAND

Qaqortoq

Nanortalik

ST. LAWRENCE RIVER

Saguenay

Quebec

Montreal

St. John

Bar Harbor

Boston

Newport

New York

Portland

Cape Cod Canal

Atlantic Ocean

Gaspé

L'Anse aux Meadows

Charlottetown

Halifax

BERMUDA

Hamilton

Charlotte Amalie

ST. THOMAS

Road Town

BRITISH VIRGIN ISLANDS

Philipsburg

ST. MARTIN

Basseterre

ST. KITTS & NEVIS

St. John's

ANTIGUA & BARBUDA

Roseau

DOMINICA

Castries

ST. LUCIA

Bridgetown

BARBADOS

Coral Sea

FIJI

Suva

COOK ISLANDS

Vaitape

Opunohu Bay

Papeete

FRENCH POLYNESIA

Taiouhae

Atuona

Tasman Sea

Waitangi

Auckland

Rotorua

Napier

Wellington

Christchurch

Dunedin

NEW ZEALAND

International Date Line

ICELAND'S NATURAL BEAUTY

Reykjavík roundtrip | 8 days | 2025 departures | From £3,890 per person

Discover Iceland's majestic shores as you explore this northern isle's coastal towns. Encounter unparalleled natural beauty and witness cascading waterfalls amid pristine fjord landscapes. Observe the wealth of wildlife, from puffins to the gentle giants of the sea. Join us for a truly immersive experience that brings you closer to nature and all her splendour.

DAY	DESTINATION	Viking ocean ships Jun-Aug 2025 departures	VERANDA	DELUXE VERANDA	PENTHOUSE VERANDA	PENTHOUSE JR. SUITE	EXPLORER SUITE	OWNER'S SUITE
1-2	REYKJAVÍK, ICELAND							
3	ÍSAFJÖRDUR, ICELAND	Pricing per person from:	£3,890	£3,990	£4,790	£6,190	£7,790	£11,790
4	AKUREYRI, ICELAND							
5	SEYDISFJÖRDUR, ICELAND							
6	DJÚPIVOGUR, ICELAND							
7	WESTMAN ISLANDS (HEIMAÆY), ICELAND							
8	REYKJAVÍK, ICELAND							

One complimentary shore excursion in almost every port of call
Sequence and ports of call are subject to change.



SELJALANDSFOSS WATERFALL

Terms and conditions: Prices and availability are correct at the time of going to print but are subject to change. Prices are per person based on double occupancy. From prices are based on two people sharing the lowest grade stateroom, departing on selected dates in 2025. Single supplements 100%. Please see back page for full terms and conditions.

SOUTH AMERICA & THE CHILEAN FJORDS

Buenos Aires to Santiago | 18 days | 2025 departures | From £7,490 per person

Soak in the eclectic mix of Latin and European influences in the Argentine capital of Buenos Aires. Visit Port Stanley and explore the scenic surroundings of Ushuaia, the city at the "End of the World". Sail through the Strait of Magellan, passing rugged mountain peaks and blue-tinted icebergs, and experience the vibrant atmosphere of Chile's seafaring capital, Santiago.

DAY	DESTINATION	Viking ocean ships Jan-Mar 2025 departures	VERANDA	DELUXE VERANDA	PENTHOUSE VERANDA	PENTHOUSE JR. SUITE	EXPLORER SUITE	OWNER'S SUITE
1-2	BUENOS AIRES, ARGENTINA							
3	MONTEVIDEO, URUGUAY	Pricing per person from:	£7,490	£7,790	£9,490	£13,090	£16,490	£25,990
4-5	SAIL THE ATLANTIC OCEAN							
6	PUERTO MADRYN, ARGENTINA							
7	SAIL THE ATLANTIC OCEAN							
8	PORT STANLEY, FALKLAND ISLANDS							
9	SAIL THE ATLANTIC OCEAN							
10	SCENIC SAILING: CAPE HORN							
11	USHUAIA, ARGENTINA							
12	PUNTA ARENAS, CHILE							
13	SCENIC SAILING: AMALIA GLACIER							
14	SCENIC SAILING: CHILEAN FJORDS							
15	PUERTO MONTT, CHILE							
16	SAIL THE PACIFIC OCEAN							
17-18	SANTIAGO (VALPARAÍSO), CHILE							

One complimentary shore excursion in almost every port of call
Sequence and ports of call are subject to change.
This itinerary is also available in the reverse direction.



CHILEAN FJORDS

Terms and conditions: Prices and availability are correct at the time of going to print but are subject to change. Prices are per person based on double occupancy. From prices are based on two people sharing the lowest grade stateroom, departing on selected dates in 2025. Single supplements 100%. Please see back page for full terms and conditions.

EMPIRES OF THE MEDITERRANEAN

Venice (Chioggia) to Athens (Piraeus) | 10 days | 2025 departures | From £4,340 per person

Sail the Adriatic and Aegean, taking in all the riches of this fabled region. On an exploration bookended by iconic Venice and Athens, discover the ancient ruins of Olympia and the Acropolis. Explore the medieval warrens of Zadar and Dubrovnik, and admire the famed whitewashed villages of Santorini. Delight in the beauty of Corfu and be captivated by Koper.

DAY	DESTINATION	Viking ocean ships Mar-Aug 2025	VERANDA	DELUXE VERANDA	PENTHOUSE VERANDA	PENTHOUSE JR. SUITE	EXPLORER SUITE	OWNER'S SUITE
1	VENICE (CHIOGGIA), ITALY							
2	KOPER, SLOVENIA	Pricing per person from:	£4,340	£4,490	£5,290	£6,290	£7,790	£13,390
3	ZADAR, CROATIA							
4	DUBROVNIK, CROATIA							
5	KOTOR, MONTENEGRO							
6	CORFU, GREECE							
7	KATAKOLON, GREECE							
8	SANTORINI (THÍRA), GREECE							
9-10	ATHENS (PIRAEUS), GREECE							

One complimentary shore excursion in almost every port of call. Sequence and ports of call are subject to change. This itinerary is also available in the reverse direction.



VIKING OCEAN SHIP, DUBROVNIK

Terms and conditions: Prices and availability are correct at the time of going to print but are subject to change. Prices are per person based on double occupancy. From prices are based on two people sharing the lowest grade stateroom, departing on selected dates in 2025. Single supplements 100%. Please see back page for full terms and conditions.

VIKING HOMELANDS

Stockholm to Bergen | 15 days | 2025 departures | From £6,090 per person

Sail historic waters and discover more of Scandinavia with overnights in Stockholm, Oslo and scenic Bergen. See charming Ålborg and Gdańsk, and visit the grand cities of Berlin and Copenhagen. Witness breathtaking scenery from your ship as she glides through majestic Norwegian fjords in the legendary homelands of the Vikings.

DAY	DESTINATION	Viking ocean ships Apr-Aug 2025 departures	VERANDA	DELUXE VERANDA	PENTHOUSE VERANDA	PENTHOUSE JR. SUITE	EXPLORER SUITE	OWNER'S SUITE
1-2	STOCKHOLM, SWEDEN							
3	MARIEHAMN, ÅLAND ISLANDS	Pricing per person from:	£6,090	£6,290	£7,190	£9,090	£11,090	£16,690
4	SAIL THE SWEDISH COAST							
5	GDAŃSK, POLAND							
6	BORNHOLM, DENMARK							
7	BERLIN, GERMANY							
8	COPENHAGEN, DENMARK							
9	ÅLBORG, DENMARK							
10-11	OSLO, NORWAY							
12	STAVANGER, NORWAY							
13	EIDFJORD, NORWAY							
14-15	BERGEN, NORWAY							

One complimentary shore excursion in almost every port of call. Sequence and ports of call are subject to change. This itinerary is also available in the reverse direction.



NYHAVN, COPENHAGEN

Terms and conditions: Prices and availability are correct at the time of going to print but are subject to change. Prices are per person based on double occupancy. From prices are based on two people sharing the lowest grade stateroom, departing on selected dates in 2025. Single supplements 100%. Please see back page for full terms and conditions.

INTO THE MIDNIGHT SUN

Bergen to London | 15 days | 2025 departures | From £5,990 per person

Traverse deep-cut fjords along the fabled Norwegian coast. Sail across the Arctic. Follow in the footsteps of Vikings between the remote North Cape and the windswept Shetland and Orkney Islands of Scotland. Enjoy an overnight stay in the former Hanseatic League city of Bergen and visit the Scottish capital of Edinburgh, where medieval glory mingles with classic beauty.

DAY	DESTINATION	Viking ocean ships Jun-Jul 2025 departures	VERANDA	DELUXE VERANDA	PENTHOUSE VERANDA	PENTHOUSE JR. SUITE	EXPLORER SUITE	OWNER'S SUITE
1-2	BERGEN, NORWAY							
3	GEIRANGER, NORWAY	Pricing per person from:	£5,990	£6,290	£7,590	£9,490	£11,990	SOLD OUT
4	SAIL THE NORWEGIAN SEA							
5	LOFOTEN (LEKNES), NORWAY							
6	TROMSØ, NORWAY							
7	HONNINGSVÅG, NORWAY							
8-9	SAIL THE NORWEGIAN SEA							
10	SHETLAND ISLANDS (LERWICK), SCOTLAND							
11	ORKNEY ISLANDS (KIRKWALL), SCOTLAND							
12	EDINBURGH (NEWHAVEN HARBOUR), SCOTLAND							
13	SAIL THE NORTH SEA							
14-15	LONDON (GREENWICH), ENGLAND							



BERGEN, NORWAY

One complimentary shore excursion in almost every port of call. Sequence and ports of call are subject to change. This itinerary is also available in the reverse direction.

Terms and conditions: Prices and availability are correct at the time of going to print but are subject to change. Prices are per person based on double occupancy. From prices are based on two people sharing the lowest grade stateroom, departing on selected dates in 2025. Single supplements 100%. Please see back page for full terms and conditions.

WEST INDIES EXPLORER

San Juan roundtrip | 11 days | 2025 departures | From £4,290 per person

Sail from historic San Juan to the colourful Caribbean. Avoid long days at sea associated with most Caribbean cruises and spend more time discovering rich island cultures. Immerse yourself in the British, French and Dutch cultures of the Lesser Antilles as you sail azure waters from Tortola and St. Lucia to Dominica, St. Martin and St. Thomas.

DAY	DESTINATION	Viking ocean ships Jan-Mar 2025 departures	VERANDA	DELUXE VERANDA	PENTHOUSE VERANDA	PENTHOUSE JR. SUITE	EXPLORER SUITE	OWNER'S SUITE
1-2	SAN JUAN, PUERTO RICO							
3	TORTOLA (ROAD TOWN), BRITISH VIRGIN ISLANDS	Pricing per person from:	£4,290	£4,490	£5,290	£7,090	£8,690	£13,290
4	ST. KITTS (BASSETERRE), ST. KITTS & NEVIS							
5	CASTRIES, ST. LUCIA							
6	BRIDGETOWN, BARBADOS							
7	ROSEAU, DOMINICA							
8	ANTIGUA (ST. JOHN'S), ANTIGUA AND BARBUDA							
9	PHILIPSBURG, ST. MARTIN							
10	ST. THOMAS (CHARLOTTE AMALIE), U.S. VIRGIN ISLANDS							
11	SAN JUAN, PUERTO RICO							



OLD SAN JUAN, PUERTO RICO

One complimentary shore excursion in almost every port of call. Sequence and ports of call are subject to change.

Terms and conditions: Prices and availability are correct at the time of going to print but are subject to change. Prices are per person based on double occupancy. From prices are based on two people sharing the lowest grade stateroom, departing on selected dates in 2025. Single supplements 100%. Please see back page for full terms and conditions.

ALASKA & THE INSIDE PASSAGE

Vancouver to Seward | 11 days | 2025 departures | From £5,040 per person

Immerse yourself in a world of Tlingit heritage and experience the outpost atmosphere that prevails in charming, mountain-ringed seaside towns. As you sail this pristine wilderness of misty fjords, lush forests and gleaming walls of ice, pan for gold like prospectors of old, and meet local Tlingit who have fished these waters for centuries.

DAY	DESTINATION	Viking ocean ships May-Sep 2025 departures	VERANDA	DELUXE VERANDA	PENTHOUSE VERANDA	PENTHOUSE JR. SUITE	EXPLORER SUITE	OWNER'S SUITE
1	VANCOUVER, BRITISH COLUMBIA, CANADA							
		Pricing per person from:	£5,040	£5,190	£6,090	£8,290	£11,090	£16,990
2	SCENIC SAILING: THE INSIDE PASSAGE							
3	KETCHIKAN, UNITED STATES							
4	SITKA, UNITED STATES							
5	JUNEAU, UNITED STATES							
6	SKAGWAY, UNITED STATES							
7	ICY STRAIT POINT, UNITED STATES							
8	SCENIC SAILING: YAKUTAT BAY							
9	VALDEZ, UNITED STATES							
10-11	SEWARD, UNITED STATES							



MENDENHALL GLACIER, JUNEAU, ALASKA

One complimentary shore excursion in almost every port of call. Sequence and ports of call are subject to change. This itinerary is also available in the reverse direction.

Terms and conditions: Prices and availability are correct at the time of going to print but are subject to change. Prices are per person based on double occupancy. From prices are based on two people sharing the lowest grade stateroom, departing on selected dates in 2025. Single supplements 100%. Please see back page for full terms and conditions.

ANCIENT ADRIATIC TREASURES

Venice (Chioggia) to Istanbul | 15 days | 2025 departures | From £7,090 per person

Discover Adriatic and Aegean treasures on this journey that combines Venice, the Adriatic & Greece and Ancient Mediterranean Treasures. Overnight amid Venice's canals and call on the walled city of Dubrovnik. Walk through Kotor's medieval streets, marvel at Olympia's ancient ruins and enjoy a stay in Athens. Explore Troy's archaeological marvels, a UNESCO Site, and spend two days in Istanbul.

DAY	DESTINATION	Viking ocean ships Apr-Aug 2025 departures	VERANDA	DELUXE VERANDA	PENTHOUSE VERANDA	PENTHOUSE JR. SUITE	EXPLORER SUITE	OWNER'S SUITE
1-2	VENICE (CHIOGGIA), ITALY							
		Pricing per person from:	£7,090	£7,190	£8,990	£11,990	£15,990	SOLD OUT
3	SPLIT, CROATIA							
4	DUBROVNIK, CROATIA							
5	KOTOR, MONTENEGRO							
6	CORFU, GREECE							
7	KATAKOLON, GREECE							
8-9	ATHENS (PIRAEUS), GREECE							
10	CRETE (HERAKLION), GREECE							
11	RHODES, GREECE							
12	EPHESUS (KUŞADASI), TURKEY							
13	TROY (ÇANAĞKALE), TURKEY							
14-15	ISTANBUL, TURKEY							



SANTA MARIA DELLA SALUTE, VENICE

One complimentary shore excursion in almost every port of call. Sequence and ports of call are subject to change. This itinerary is also available in the reverse direction.

Terms and conditions: Prices and availability are correct at the time of going to print but are subject to change. Prices are per person based on double occupancy. From prices are based on two people sharing the lowest grade stateroom, departing on selected dates in 2025. Single supplements 100%. Please see back page for full terms and conditions.

IN SEARCH OF THE NORTHERN LIGHTS

London to Bergen | 13 days | 2025 departures | From £4,540 per person

Experience a land where dawn and twilight merge on the edges of the long Arctic night. Sailing far north during Norway's winter, witness snow-covered landscapes dotted with rugged mountains and steep fjords, and seek out the brilliant aurora borealis dancing in the night sky. Delve into Sami legends and World War II history, and pilot a dog sled or snowmobile.

DAY	DESTINATION	Viking ocean ships Jan-Mar 2025 departures	VERANDA	DELUXE VERANDA	PENTHOUSE VERANDA	PENTHOUSE JR. SUITE	EXPLORER SUITE	OWNER'S SUITE
1	LONDON (TILBURY), ENGLAND							
2	AMSTERDAM (IJMUIDEN), THE NETHERLANDS	Pricing per person from:	£4,540	£4,790	£6,290	£8,690	£11,990	£16,990
3	SAIL THE NORTH SEA							
4	SCENIC SAILING: NORWEGIAN INSIDE PASSAGE							
5	NARVIK, NORWAY							
6-7	TROMSØ, NORWAY							
8-9	ALTA, NORWAY							
10-11	SCENIC SAILING: NORWEGIAN INSIDE PASSAGE							
12-13	BERGEN, NORWAY							



NORTHERN LIGHTS, BERGEN, NORWAY

One complimentary shore excursion in almost every port of call. Sequence and ports of call are subject to change. This itinerary is also available in the reverse direction.

Terms and conditions: Prices and availability are correct at the time of going to print but are subject to change. Prices are per person based on double occupancy. From prices are based on two people sharing the lowest grade stateroom, departing on selected dates in 2025. Single supplements 100%. Please see back page for full terms and conditions.

AUSTRALIA & NEW ZEALAND

Sydney to Auckland | 15 days | 2025 departures | From £7,590 per person

Gain deep insight into the native and European cultures of Australia and New Zealand. Hear about Sydney's and Hobart's penal past. Admire the Victorian treasures of Dunedin, the fragrant English gardens of Christchurch and Wellington and the art deco glories of Napier. Enjoy the sounds of the didgeridoo and the thrilling dances of the Māori, on an unforgettable voyage 'down under'.

DAY	DESTINATION	Viking ocean ships Jan-Mar 2025 departures	VERANDA	DELUXE VERANDA	PENTHOUSE VERANDA	PENTHOUSE JR. SUITE	EXPLORER SUITE	OWNER'S SUITE
1-2	SYDNEY, AUSTRALIA							
3	SAIL THE GIPPSLAND COAST	Pricing per person from:	£7,590	£7,790	£9,790	£12,590	SOLD OUT	SOLD OUT
4	MELBOURNE, AUSTRALIA							
5	SCENIC SAILING: BASS STRAIT							
6	TASMANIA, AUSTRALIA							
7	SAIL THE TASMAN SEA							
8	SCENIC SAILING: FOVEAUX STRAIT							
9	DUNEDIN, NEW ZEALAND							
10	CHRISTCHURCH, NEW ZEALAND							
11	WELLINGTON, NEW ZEALAND							
12	NAPIER, NEW ZEALAND							
13	ROTORUA, NEW ZEALAND							
14-15	AUCKLAND, NEW ZEALAND							



VIKING OCEAN SHIP, SYDNEY

One complimentary shore excursion in almost every port of call. Sequence and ports of call are subject to change. This itinerary is also available in the reverse direction.

Terms and conditions: Prices and availability are correct at the time of going to print but are subject to change. Prices are per person based on double occupancy. From prices are based on two people sharing the lowest grade stateroom, departing on selected dates in 2025. Single supplements 100%. Please see back page for full terms and conditions.

ACROSS THE BAY OF BENGAL

Mumbai to Bangkok (Laem Chabang) | 16 days | 2025 departures | From £6,390 per person

Discover Sri Lanka's colonial history during its time as Ceylon and explore India's Portuguese heritage in Goa. Experience Malaysia's richly spiritual culture. In Singapore, get a taste of the city's cultural diversity and mingle with shoppers at a traditional Bangkok market. Overnights in Mumbai, Colombo and Bangkok help you explore fully.

DAY	DESTINATION	Viking ocean ships Mar 2025 departures	VERANDA	DELUXE VERANDA	PENTHOUSE VERANDA	PENTHOUSE JR. SUITE	EXPLORER SUITE	OWNER'S SUITE
1-2	MUMBAI, INDIA							
3	GOA (MORMUGAO), INDIA	Pricing per person from:	SOLD OUT	£6,390	£8,090	£12,490	£17,090	SOLD OUT
4	SAIL THE LACCADIVE SEA							
5-6	COLOMBO, SRI LANKA							
7-8	SCENIC SAILING: THE BAY OF BENGAL							
9	SCENIC SAILING: STRAIT OF MALACCA							
10	GEORGE TOWN, MALAYSIA							
11	KUALA LUMPUR (PORT KLANG), MALAYSIA							
12	SINGAPORE, SINGAPORE							
13	SCENIC SAILING: GULF OF THAILAND							
14	KOH SAMUI (NATHON), THAILAND							
15-16	BANGKOK (LAEM CHABANG), THAILAND							



MUMBAI HARBOUR, INDIA

One complimentary shore excursion in almost every port of call. Sequence and ports of call are subject to change. This itinerary is also available in the reverse direction.

Terms and conditions: Prices and availability are correct at the time of going to print but are subject to change. Prices are per person based on double occupancy. Single supplements 100%. Please see back page for full terms and conditions.

ITALIAN SOJOURN

Rome to Venice (Chioggia) | 8 days | 2025 departures | From £3,040 per person

Experience the legacies of civilisations, cruising Italy between Civitavecchia and Venice. Discover the magnificent Amalfi Coast from Naples and visit Messina, Sicily's cultural crossroads. Hear the echoes of ancient Greece in Crotona and witness the beauty of Puglia in Bari. Explore historic Šibenik, Croatia's oldest coastal town. An overnight in Venice lets you immerse yourself in Italy's most romantic city.

DAY	DESTINATION	Viking ocean ships Jan; Mar-Aug 2025 departures	VERANDA	DELUXE VERANDA	PENTHOUSE VERANDA	PENTHOUSE JR. SUITE	EXPLORER SUITE	OWNER'S SUITE
1	ROME (CIVITAVECCHIA), ITALY							
2	NAPLES, ITALY	Pricing per person from:	SOLD OUT	£3,040	£3,490	£3,990	£5,090	SOLD OUT
3	SICILY, ITALY							
4	CROTONE, ITALY							
5	BARI, ITALY							
6	ŠIBENIK, CROATIA							
7-8	VENICE (CHIOGGIA), ITALY							



ST. PETER'S BASILICA, VATICAN CITY

One complimentary shore excursion in almost every port of call. Sequence and ports of call are subject to change. This itinerary is also available in the reverse direction.

Terms and conditions: Prices and availability are correct at the time of going to print but are subject to change. Prices are per person based on double occupancy. From prices are based on two people sharing the lowest grade stateroom, departing on selected dates in 2025. Single supplements 100%. Please see back page for full terms and conditions.

SOUTHEAST ASIA & HONG KONG

Bangkok to Hong Kong | 15 days | 2025 departures | From £6,190 per person

Immerse yourself in the cultural tapestry of four Southeast Asian countries on one sweeping journey. Mingle with merchants at vast indoor emporiums and intimate floating markets. Meet monks at revered temples and artisans in their workshops. And witness life on Ha Long Bay as you explore by authentic junk. Uncover the nuances of Indochina with Viking.

DAY	DESTINATION	Viking ocean ships Apr 2025 departures	VERANDA	DELUXE VERANDA	PENTHOUSE VERANDA	PENTHOUSE JR. SUITE	EXPLORER SUITE	OWNER'S SUITE
1-2	BANGKOK, (LAEM CHABANG), THAILAND	Pricing per person from:	£6,190	£6,390	£9,590	£14,090	SOLD OUT	SOLD OUT
3-4	SIHANOUKVILLE, CAMBODIA							
5	SCENIC SAILING: GULF OF THAILAND							
6-8	HO CHI MINH CITY, VIETNAM							
9	SAIL THE SOUTH CHINA SEA							
10	HUE (CHAN MAY), VIETNAM							
11-12	HA LONG BAY, VIETNAM							
13	SAIL THE SOUTH CHINA SEA							
14-15	HONG KONG, CHINA							

One complimentary shore excursion in almost every port of call. Sequence and ports of call are subject to change. This itinerary is also available in the reverse direction.



VICTORIA HARBOUR, HONG KONG

Terms and conditions: Prices and availability are correct at the time of going to print but are subject to change. Prices are per person based on double occupancy. From prices are based on two people sharing the lowest grade stateroom, departing on selected dates in 2025. Single supplements 100%. Please see back page for full terms and conditions.

PANAMA CANAL & CENTRAL AMERICA

Ft. Lauderdale roundtrip | 15 days | 2025 Departures | From £4,790 per person

Trace the coast of Central America, uncovering rich history, culture and natural beauty. Discover the colonial past of Cozumel, and glimpse Belize's Mayan civilisation and Panama's Emberá people. Gaze upon white-sand beaches and turquoise waters in Honduras and lush rainforests in Costa Rica. Marvel at the workings of the Panama Canal and admire a blend of past and present in Jamaica.

DAY	DESTINATION	Viking ocean ships Jan-Mar 2025 departures	VERANDA	DELUXE VERANDA	PENTHOUSE VERANDA	PENTHOUSE JR. SUITE	EXPLORER SUITE	OWNER'S SUITE
1	FT. LAUDERDALE, FLORIDA, UNITED STATES	Pricing per person from:	£4,790	£4,990	£5,990	£8,190	£11,390	£16,990
2-3	SAIL THE CARIBBEAN SEA							
4	MONTEGO BAY, JAMAICA							
5	SAIL THE CARIBBEAN SEA							
6	SCENIC SAILING: PANAMA CANAL PARTIAL TRANSIT							
7	COLÓN, PANAMA							
8	PUERTO LIMÓN, COSTA RICA							
9	SAIL THE CARIBBEAN SEA							
10	ROATÁN, HONDURAS							
11	BELIZE CITY, BELIZE							
12	COZUMEL, MEXICO							
13-14	SAIL THE CARIBBEAN SEA							
15	FT. LAUDERDALE, FLORIDA, UNITED STATES							

One complimentary shore excursion in almost every port of call. Sequence and ports of call are subject to change.



MONTEGO BAY, JAMAICA

Terms and conditions: Prices and availability are correct at the time of going to print but are subject to change. Prices are per person based on double occupancy. From prices are based on two people sharing the lowest grade stateroom, departing on selected dates in 2025. Single supplements 100%. Please see back page for full terms and conditions.

KOMODO & THE AUSTRALIAN COAST

Sydney to Bali (Benoa) | 17 days | 2025 departures | From £7,190 per person

Discover the natural wonders of the Indonesian archipelago and Australia's legendary coast. Meet the region's diverse residents, from Komodo dragons to jumping crocodiles, and visit charming island locales. Witness colourful traditions and meet local craft artists. Explore Komodo National Park. Experience charismatic Darwin and uncover the cosmopolitan culture of Brisbane with a welcoming guide.

DAY	DESTINATION	Viking ocean ships Feb-Mar 2025 departures	VERANDA	DELUXE VERANDA	PENTHOUSE VERANDA	PENTHOUSE JR. SUITE	EXPLORER SUITE	OWNER'S SUITE
1	SYDNEY, AUSTRALIA							
2	NEWCASTLE, AUSTRALIA							
3	SAIL THE AUSTRALIAN COAST	Pricing per person from:	£7,190	£7,390	£10,390	£16,490	£20,490	SOLD OUT
4	BRISBANE, AUSTRALIA							
5	SAIL THE AUSTRALIAN COAST							
6	WHITSUNDAY ISLANDS (AIRLIE BEACH), AUSTRALIA							
7	TOWNSVILLE, AUSTRALIA							
8	CAIRNS, AUSTRALIA							
9	SAIL THE CORAL SEA							
10	THURSDAY ISLAND, AUSTRALIA							
11	SAIL THE ARAFURA SEA							
12-13	DARWIN, AUSTRALIA							
14	SAIL THE TIMOR SEA							
15	KOMODO NATIONAL PARK (SLAWI BAY), INDONESIA							
16	LOMBOK, INDONESIA							
17	BALI (BENOA), INDONESIA							



RICE TERRACE, BALI

One complimentary shore excursion in almost every port of call. Sequence and ports of call are subject to change. This itinerary is also available in the reverse direction.

Terms and conditions: Prices and availability are correct at the time of going to print but are subject to change. Prices are per person based on double occupancy. From prices are based on two people sharing the lowest grade stateroom, departing on selected dates in 2025. Single supplements 100%. Please see back page for full terms and conditions.

MEDITERRANEAN ODYSSEY

Barcelona to Venice (Chioggia) | 13 days | 2025 departures | From £5,340 per person

Explore some of the Mediterranean's most historic ports: the fabled towns of Tuscany, ancient Rome and canal-laced Venice. Enjoy ample time to savour Barcelona's easygoing spirit with an overnight stay. Discover the French Riviera in Marseille and Monte Carlo. And visit Dubrovnik, a medieval jewel. Along the way, gracious hosts and fine regional cuisine connect you to this remarkable region.

DAY	DESTINATION	Viking ocean ships Mar-Aug 2025 departures	VERANDA	DELUXE VERANDA	PENTHOUSE VERANDA	PENTHOUSE JR. SUITE	EXPLORER SUITE	OWNER'S SUITE
1-2	BARCELONA, SPAIN							
3	MARSEILLE, FRANCE	Pricing per person from:	£5,340	£5,490	£6,790	£8,290	£9,990	£15,090
4	MONTE CARLO, MONACO							
5	FLORENCE/PISA, ITALY							
6	ROME (CIVITAVECCHIA), ITALY							
7	NAPLES, ITALY							
8	SAIL THE IONIAN SEA							
9	CORFU, GREECE							
10	DUBROVNIK, CROATIA							
11	SPLIT, CROATIA							
12-13	VENICE (CHIOGGIA), ITALY							



VIKING OCEAN SHIP, DUBROVNIK, CROATIA

One complimentary shore excursion in almost every port of call. Sequence and ports of call are subject to change. This itinerary is also available in the reverse direction.

Terms and conditions: Prices and availability are correct at the time of going to print but are subject to change. Prices are per person based on double occupancy. From prices are based on two people sharing the lowest grade stateroom, departing on selected dates in 2025. Single supplements 100%. Please see back page for full terms and conditions.

ICELAND & NORWAY'S ARCTIC EXPLORER

Bergen to Reykjavik | 15 days | 2025 departures | From £6,090 per person

Discover life in the far north during a voyage across the Arctic Circle and along the distant shores of Norway and Iceland. Marvel at the rugged beauty of Geiranger, visit charming Bergen and admire Honningsvåg's remote North Cape. Enjoy an overnight stay in Longyearbyen, home to more polar bears than people, and call at Tromsø, Norway's most northerly city.

DAY	DESTINATION	Viking ocean ships May-Jun 2025 departures	VERANDA	DELUXE VERANDA	PENTHOUSE VERANDA	PENTHOUSE JR. SUITE	EXPLORER SUITE	OWNER'S SUITE
1-2	BERGEN, NORWAY		£6,090	£6,290	£7,590	£10,290	SOLD OUT	SOLD OUT
3	GEIRANGER, NORWAY							
4	SCENIC SAILING: NORWEGIAN INSIDE PASSAGE							
5	NARVIK, NORWAY							
6	LOFOTEN (LEKNES), NORWAY							
7	TROMSØ, NORWAY							
8	HONNINGSVÅG, NORWAY							
9	SAIL THE BARENTS SEA							
10-11	LONGYEARBYEN, SVALBARD & JAN MAYEN ISLANDS							
12-13	SAIL THE NORWEGIAN SEA							
14	ÍSAFJÖRDUR, ICELAND							
15	REYKJAVÍK, ICELAND							



REYKJAVÍK, ICELAND

One complimentary shore excursion in almost every port of call. Sequence and ports of call are subject to change. This itinerary is also available in the reverse direction.

Terms and conditions: Prices and availability are correct at the time of going to print but are subject to change. Prices are per person based on double occupancy. From prices are based on two people sharing the lowest grade stateroom, departing on selected dates in 2025. Single supplements 100%. Please see back page for full terms and conditions.

IBERIAN EXPLORER

Barcelona to London | 8 days | 2025 departures | From £2,590 per person

Circumnavigate the Iberian Peninsula and uncover the historic treasures of Spain. Explore the Roman past and tranquil beauty of Cartagena and its Murcia province. Visit Málaga, the city of Picasso's birth, and Granada's Alhambra palace. Sail through the Strait of Gibraltar and into the scenic bay of Vigo, gateway to Santiago de Compostela.

DAY	DESTINATION	Viking ocean ship Jan 2025 departures	VERANDA	DELUXE VERANDA	PENTHOUSE VERANDA	PENTHOUSE JR. SUITE	EXPLORER SUITE	OWNER'S SUITE
1	BARCELONA, SPAIN		£2,590	£2,690	£2,990	£3,590	£4,590	£6,990
2	MURCIA (CARTAGENA), SPAIN							
3	GRANADA (MÁLAGA), SPAIN							
4	SAIL THE STRAIT OF GIBRALTAR							
5	VIGO, SPAIN							
6	SAIL THE ATLANTIC OCEAN							
7	PORTSMOUTH, ENGLAND							
8	LONDON (TILBURY), ENGLAND							



PARK GÜELL, BARCELONA

One complimentary shore excursion in almost every port of call. Sequence and ports of call are subject to change.

Terms and conditions: Prices and availability are correct at the time of going to print but are subject to change. Prices are per person based on double occupancy. From prices are based on two people sharing the lowest grade stateroom, departing on selected dates in 2025. Single supplements 100%. Please see back page for full terms and conditions.

AMAZON & CARIBBEAN ADVENTURE

San Juan to Manaus | 13 days | 2025 departures | From £5,340 per person

Experience picturesque scenery, rich cultures and stunning biodiversity on this voyage of discovery. Immerse yourself in San Juan, soak up Antigua's historic charms, explore St. Lucia's pristine beauty and Barbados's colonial influences. Marvel at the striking architecture of Manaus and sail the majestic Amazon River, admiring its robust plant and animal life and calling on riverside ports steeped in tradition.

DAY	DESTINATION	Viking ocean ships Jan-Mar 2025 departures	VERANDA	DELUXE VERANDA	PENTHOUSE VERANDA	PENTHOUSE JR. SUITE	EXPLORER SUITE	OWNER'S SUITE
1-2	SAN JUAN, PUERTO RICO							
3	ANTIGUA (ST. JOHN'S), ANTIGUA AND BARBUDA	Pricing per person from:	£5,340	£5,490	£6,290	£7,890	£10,490	£15,990
4	CASTRIES, ST. LUCIA							
5	BRIDGETOWN, BARBADOS							
6	SAIL THE ATLANTIC OCEAN							
7	ÎLES DU SALUT, FRENCH GUIANA							
8	SAIL THE ATLANTIC OCEAN							
9	SAIL THE AMAZON RIVER							
10	SANTARÉM, BRAZIL							
11	PARINTINS, BRAZIL							
12-13	MANAUS, BRAZIL							



GROS PITON, ST. LUCIA

One complimentary shore excursion in almost every port of call. Sequence and ports of call are subject to change. This itinerary is also available in the reverse direction.

Terms and conditions: Prices and availability are correct at the time of going to print but are subject to change. Prices are per person based on double occupancy. From prices are based on two people sharing the lowest grade stateroom, departing on selected dates in 2025. Single supplements 100%. Please see back page for full terms and conditions.

BRITISH ISLES EXPLORER

Bergen to London | 15 days | 2025 departures | From £5,690 per person

Immerse yourself in the British Isles with overnight stays in Bergen, Norway, and Greenwich, England. Discover the legendary Highlands and Western Isles of Scotland and its capital, Edinburgh. Visit the Shetland and Orkney Islands, and contrast modern Belfast with traditional Dublin. Witness Welsh culture in Snowdonia. In England, visit maritime Liverpool, see historic Dover and enjoy a tour of London.

DAY	DESTINATION	Viking ocean ships Mar-Sep 2025 departures	VERANDA	DELUXE VERANDA	PENTHOUSE VERANDA	PENTHOUSE JR. SUITE	EXPLORER SUITE	OWNER'S SUITE
1-2	BERGEN, NORWAY							
3	SHETLAND ISLANDS (LERWICK), SCOTLAND	Pricing per person from:	£5,690	£5,890	£6,790	£8,690	£11,890	£16,990
4	THE HIGHLANDS (INVERGORDON), SCOTLAND							
5	EDINBURGH (NEWHAVEN HARBOUR), SCOTLAND							
6	ORKNEY ISLANDS (KIRKWALL), SCOTLAND							
7	THE HIGHLANDS (ULLAPOOL), SCOTLAND							
8	BELFAST, NORTHERN IRELAND							
9	LIVERPOOL, ENGLAND							
10	HOLYHEAD, WALES							
11	DUBLIN, IRELAND							
12	SCENIC SAILING: ENGLISH CHANNEL							
13	DOVER, ENGLAND							
14-15	LONDON (GREENWICH), ENGLAND							



BERGEN, NORWAY

One complimentary shore excursion in almost every port of call. Sequence and ports of call are subject to change. This itinerary is also available in the reverse direction.

Terms and conditions: Prices and availability are correct at the time of going to print but are subject to change. Prices are per person based on double occupancy. From prices are based on two people sharing the lowest grade stateroom, departing on selected dates in 2025. Single supplements 100%. Please see back page for full terms and conditions.

ANCIENT MEDITERRANEAN TREASURES

Istanbul to Athens (Piraeus) | 8 days | 2025 departures | From £3,390 per person

Witness the origin of civilisation as you sail the Aegean Sea. Spend two days in Istanbul, with its Byzantine treasures and blend of Eastern and Western influences. Travel to the ruins of Troy, long steeped in myth. See historic sites in Ephesus and marvel at the gorgeous islands of Rhodes and Crete. Discover the architectural gems of ancient Athens during an overnight stay.

DAY	DESTINATION	Viking ocean ships Apr-Aug 2025 departures	VERANDA	DELUXE VERANDA	PENTHOUSE VERANDA	PENTHOUSE JR. SUITE	EXPLORER SUITE	OWNER'S SUITE
1-2	ISTANBUL, TURKEY							
3	TROY (ÇANAKKALE), TURKEY	Pricing per person from:	£3,390	£3,590	£4,390	£5,390	£7,390	SOLD OUT
4	EPHESUS (KUŞADASI), TURKEY							
5	RHODES, GREECE							
6	CRETE (HERAKLION), GREECE							
7-8	ATHENS (PIRAEUS), GREECE							

One complimentary shore excursion in almost every port of call. Sequence and ports of call are subject to change. This itinerary is also available in the reverse direction.



HAGIA SOPHIA, ISTANBUL

Terms and conditions: Prices and availability are correct at the time of going to print but are subject to change. Prices are per person based on double occupancy. From prices are based on two people sharing the lowest grade stateroom, departing on selected dates in 2025. Single supplements 100%. Please see back page for full terms and conditions.

TRADE ROUTES OF THE MIDDLE AGES

Barcelona to Bergen | 15 days | 2025 departures | From £5,290 per person

Trace medieval routes of commerce during a 15-day journey bookended by overnight stays in Bergen and Barcelona. Explore three of Europe's most picturesque cities: Amsterdam, Bruges and Paris. Call on the historic ports of Portsmouth and Falmouth and admire the neoclassical gems of Porto. Explore Málaga, gateway to Granada's stunning Alhambra palace, and explore Cartagena.

DAY	DESTINATION	Viking ocean ships Apr-May 2025 departures	VERANDA	DELUXE VERANDA	PENTHOUSE VERANDA	PENTHOUSE JR. SUITE	EXPLORER SUITE	OWNER'S SUITE
1-2	BARCELONA, SPAIN							
3	MURCIA (CARTAGENA), SPAIN	Pricing per person from:	£5,290	£5,590	£6,490	£8,290	£11,090	SOLD OUT
4	GRANADA (MÁLAGA), SPAIN							
5	SAIL THE ATLANTIC OCEAN							
6	PORTO, PORTUGAL							
7	SAIL THE ATLANTIC OCEAN							
8	FALMOUTH, ENGLAND							
9	PORTSMOUTH, ENGLAND							
10	PARIS (LE HAVRE), FRANCE							
11-12	BRUGES, BELGIUM							
13	SAIL THE NORTH SEA							
14-15	BERGEN, NORWAY							

One complimentary shore excursion in almost every port of call. Sequence and ports of call are subject to change. This itinerary is also available in the reverse direction.



ALHAMBRA, GRANADA, SPAIN

Terms and conditions: Prices and availability are correct at the time of going to print but are subject to change. Prices are per person based on double occupancy. From prices are based on two people sharing the lowest grade stateroom, departing on selected dates in 2025. Single supplements 100%. Please see back page for full terms and conditions.

BANGKOK, BALI & BEYOND

Bali (Benoa) to Bangkok (Laem Chabang) | 13 days | 2025 departures | From £5,390 per person

Witness the fascinating juxtapositions of Southeast Asia, where long-held traditions infuse bustling capitals. See the floating markets of Bangkok. Marvel at Kuala Lumpur's soaring Petronas Towers. Absorb the vast cultural diversity of Singapore. And gain unmatched insight into the spiritual and arts culture of Java, from the enormous temple of Borobudur to the historic riches of Jakarta and Surabaya.

DAY	DESTINATION	Viking ocean ships Mar-Apr 2025 departures	VERANDA	DELUXE VERANDA	PENTHOUSE VERANDA	PENTHOUSE JR. SUITE	EXPLORER SUITE	OWNER'S SUITE
1-2	BALI (BENOA), INDONESIA							
3	JAVA (SURABAYA), INDONESIA	Pricing per person from:	£5,390	£5,490	£8,490	£11,590	£15,590	£21,990
4	JAVA (SEMARANG), INDONESIA							
5-6	JAVA (JAKARTA), INDONESIA							
7	SAIL THE JAVA SEA							
8	SINGAPORE, SINGAPORE							
9	KUALA LUMPUR, MALAYSIA							
10	SCENIC SAILING: STRAIT OF MALACCA							
11	SCENIC SAILING: GULF OF THAILAND							
12-13	BANGKOK, (LAEM CHABANG), THAILAND							



THEAN HOU TEMPLE, KUALA LUMPUR

One complimentary shore excursion in almost every port of call. Sequence and ports of call are subject to change. This itinerary is also available in the reverse direction.

Terms and conditions: Prices and availability are correct at the time of going to print but are subject to change. Prices are per person based on double occupancy. From prices are based on two people sharing the lowest grade stateroom, departing on selected dates in 2025. Single supplements 100%. Please see back page for full terms and conditions.

JOURNEY TO ANTIQUITIES

Athens (Piraeus) to Rome | 8 days | 2025 departures | From £3,290 per person

Travel through waters once ruled by mighty empires and flourishing city-states during a cruise from Rome to Athens. Visit Naples, gateway to Pompeii, and Messina, Sicily's cultural crossroads. Discover Crete, the former seat of the once flourishing Minoan kingdom, and see remarkably preserved ancient ruins in Ephesus. Immerse yourself in Athens, the "birthplace of democracy".

DAY	DESTINATION	Viking ocean ships Feb 2025 departures	VERANDA	DELUXE VERANDA	PENTHOUSE VERANDA	PENTHOUSE JR. SUITE	EXPLORER SUITE	OWNER'S SUITE
1-2	ATHENS, (PIRAEUS), GREECE							
3	EPHESUS (KUŞADASI), TURKEY	Pricing per person from:	£3,290	£3,390	£3,890	£4,790	£6,590	£10,990
4	CRETE (SOUDA BAY), GREECE							
5	SAIL THE IONIAN SEA							
6	SICILY (MESSINA), ITALY							
7	NAPLES, ITALY							
8	ROME (CIVITAVECCHIA), ITALY							



ACROPOLIS OF ATHENS, GREECE

One complimentary shore excursion in almost every port of call. Sequence and ports of call are subject to change. This itinerary is also available in the reverse direction.

Terms and conditions: Prices and availability are correct at the time of going to print but are subject to change. Prices are per person based on double occupancy. From prices are based on two people sharing the lowest grade stateroom, departing on selected dates in 2025. Single supplements 100%. Please see back page for full terms and conditions.

DECK PLANS

Viking Ocean Ships

For interactive deck plans, photos and more on these ships, see our website.

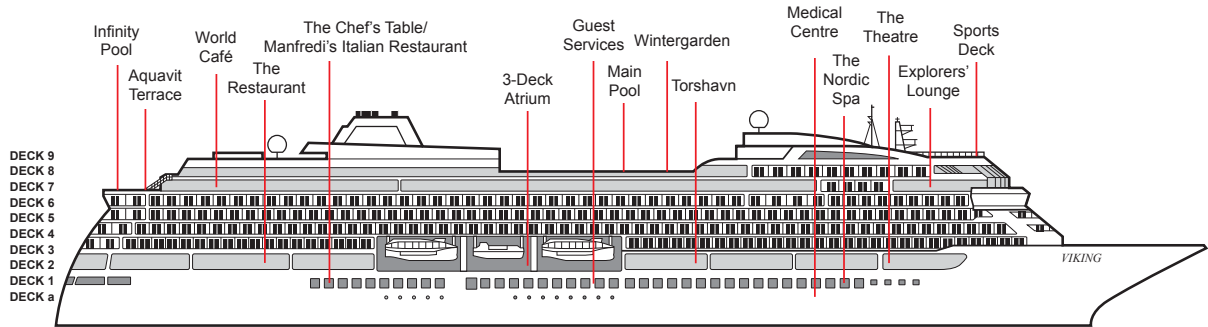

DECK 9

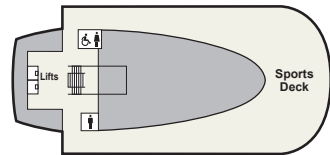

DECK 8

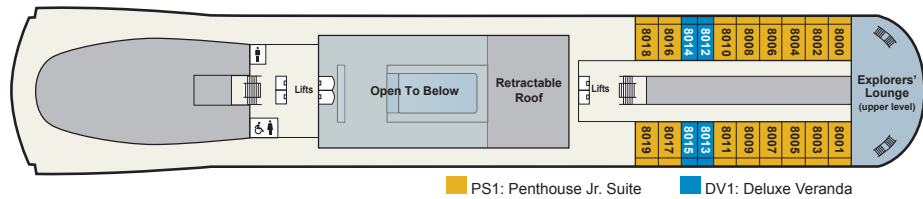

DECK 7

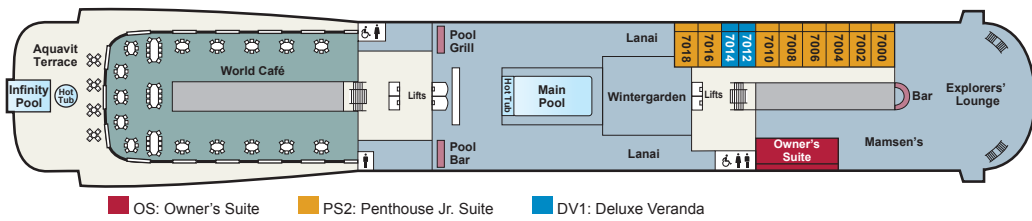

DECK 6

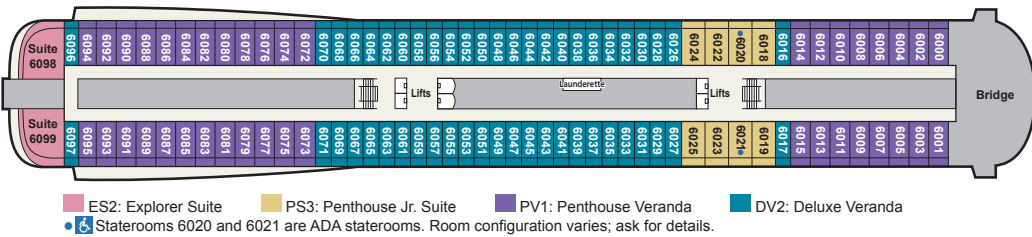

DECK 5

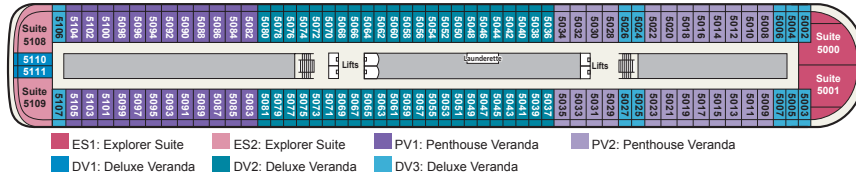

DECK 4

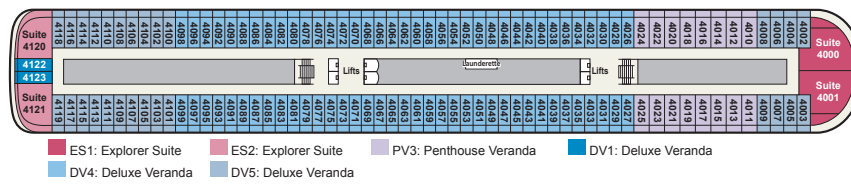

DECK 3

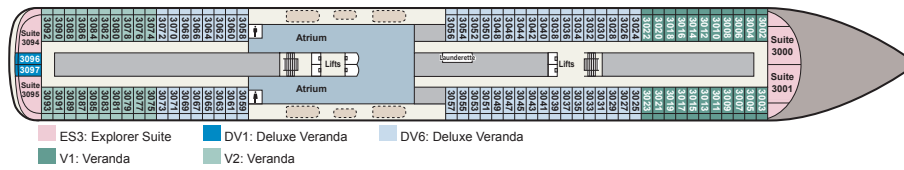

DECK 2

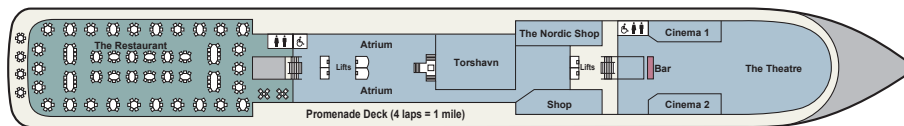

DECK 1

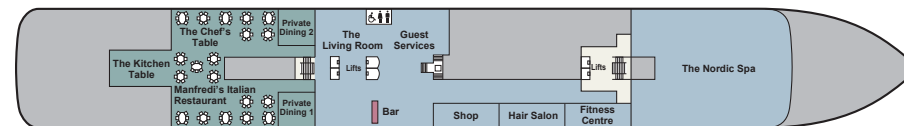

STATISTICS

Type: Small Ship (Cruising)
 GRT: 48,000
 Length: 745 ft.
 Beam: 94.5 ft.

Speed: 20 knots
 Guests: 930
 Registry: Norway

Maiden Voyages:
 Viking Star® 2015
 Viking Sea® 2016
 Viking Sky® 2017
 Viking Orion® 2018
 Viking Jupiter® 2019

Viking Venus® 2021
 Viking Mars® 2022
 Viking Neptune® 2022
 Viking Saturn® 2023

BOOKING CONDITIONS

THESE BOOKING CONDITIONS ARE THOSE THAT APPLY AS AT 6TH NOVEMBER 2023. You will be advised of the full booking conditions that apply at the time of booking. For a full copy of our current booking conditions please visit www.viking.com/legal. If you are unable to access the documentation on our website, please contact 020 8780 7900 for assistance.

INTRODUCTION

Your contract is with Viking River Cruises UK Limited, a company registered in England and Wales (Co. No.01283655) whose registered office is at Nelsons House, 83 Wimbledon Park Side, London, SW19 5LP.

Your contract incorporates these Booking Conditions and by making a booking with us you confirm your acceptance of these Booking Conditions.

'Viking', 'Viking Cruises', 'Viking River Cruises', 'Viking Ocean Cruises' and 'Viking Expedition Cruises' are trading names of Viking River Cruises UK Limited.

Your contract will constitute a package under the Package Travel and Linked Travel Arrangements Regulations 2018 ("Regulations") and set out at the end of these Booking Conditions is a summary of your key rights under the Regulations. In the unlikely event of any conflict between these Booking Conditions and the provisions of the Regulations, the provisions of the Regulations shall take precedence.

By making a booking with us, you (on behalf of yourself and all members of your party) agree to the terms of our Privacy Notice details of which are available on our website at www.viking.com or which can otherwise be provided to you in writing upon written request to data.protection@viking.com or via our offices at Viking, Nelsons House, 83 Wimbledon Park Side London SW19 5LP.

A. BOOKING AND PAYMENT

A1. YOUR RESERVATION

A1.1 When you make a booking and pay your deposit or full payment (as applicable), we will reserve your travel arrangements on the basis of these Booking Conditions. Your booking will be taken as confirmed in respect of all persons named on your booking and a binding contract between us will come into existence only upon the earlier of (a) our sending our Confirmation Invoice and/or ATOL Certificate to you or your Travel Agent or (b) the issue of tickets in your name. Prior to doing so, we or your Travel Agent may send you an acknowledgement of your booking. Any such acknowledgement simply indicates that we are dealing with your booking request and is not a confirmation of it.

A1.2 Please check your Confirmation Invoice and/ or any ATOL Certificate together with all other documents we or your Travel Agent send you as soon as you receive them. Contact us or your Travel Agent immediately if any information which appears on the Confirmation Invoice and/ or ATOL Certificate or elsewhere appears to be incorrect or incomplete, as it may not be possible to make changes later. We regret we cannot accept any responsibility if we are not notified of any inaccuracies in any document within ten days of our sending it out (five days for tickets). Whilst we will do our best to rectify any inaccuracies notified outside these time limits, you will be responsible for any costs and expenses involved in doing so except where we made the mistake and there is good reason why you did not contact us within the above time limits.

A1.3 Normally your cabin number will be advised at the time of booking or on the Confirmation Invoice but this is not guaranteed and may be altered at any time.

A1.4 At the time of booking we may not be able to confirm your exact air or rail arrangements due to airline and rail operator booking restrictions. However your Confirmation Invoice and/ or ATOL Certificate will detail those arrangements reserved for you and/ or those arrangements provisionally reserved for you and/ or those arrangements we intend to reserve for you. Please note flights may be indirect and that some airlines charge for luggage separately. In addition your arrangements may be subject to change by the relevant airline or train operator. Please also note we cannot confirm or guarantee specific airline or rail seat numbers.

A1.5 Any contract is with the "Lead Name" as shown on the Booking Form. We can only accept a booking if the Lead Name is at least 18 years old on or before the date of departure and all members of your party are at least 18 years old on or before the date of departure. Please note that you must be aged 21 or over in order to purchase or consume alcoholic beverages whilst on board our vessels.

A1.6 The Lead Name is responsible for ensuring that other members of his/her party are aware of these Booking Conditions and that they consent to him/ her acting on their behalf in dealings with us.

A1.7 If for any reason you did not see a copy of these Booking Conditions when you made your booking and, having now seen them, you now wish to cancel your booking then you may do so by returning all documentation to us or your Travel Agent within 7 days of receipt of these Booking Conditions and all monies provided by you shall be returned provided that travel has not commenced. Cancellation under this sub-clause is not permitted if your booking was made less than 10 weeks prior to travel commencing.

A2. OUR PRICE POLICY AND PAYMENT TERMS

A2.1 We reserve the right to alter prices shown in any of our brochures or in any website and we will inform you of any price changes prior to the issue of our Confirmation Invoice and/ or ATOL Certificate. Once our Confirmation Invoice and/ or ATOL Certificate has been issued then, save in the case of manifest error, any price changes may only be made in accordance with the remaining provisions of these Booking Conditions.

A2.2 When you make your booking you are required to pay a deposit of 25% of the total price. If your travel is due to commence within 10 weeks of your booking then the total price shall be payable at the time of booking. In any event the balance of the total price of your travel arrangements must be paid at least 10 weeks prior to travel commencing. Your booking will not be confirmed until we receive your deposit and if the balance is not paid by the due date then we shall cancel your booking and may levy Cancellation Charges as provided in clause D1. Any monies paid to any Travel Agent in relation to your booking are held by such Travel Agent on our behalf at all times.

A2.3 Once you have paid your deposit and our Confirmation Invoice and/ or ATOL Certificate is issued the price of your travel arrangements is fully guaranteed and will not be subject to any surcharges or alteration (save in the case of manifest error or changes requested by you to travel arrangements are made and where additional costs are incurred).

However if we do not receive the balance of the total price of your travel arrangements when due, your booking may be cancelled pursuant to clause A2.2 (and levy Cancellation Charges as provided in clause D1) and any re-booking may well be at a higher price.

A2.4 Please note that from time to time airlines alter their baggage allowance policies and this may occur after we issue our Confirmation Invoice and/ or the ATOL certificate. We have no control over any such changes and you will be responsible for any additional charges that the relevant airline may levy in respect of checked-in luggage that exceeds any limits in such altered baggage allowance policy.

A3. WHAT IS INCLUDED AND EXCLUDED IN THE COST OF YOUR HOLIDAY

A3.1 The details of what is included in the cost of your holiday is set out in the individual tour package details in our brochure or on our website.

A3.2 Any further items or services purchased on board or through our online booking management system are not included in the costs of your holiday.

B. CHANGES AND CANCELLATION BY US

B1. IF WE CHANGE YOUR TRAVEL ARRANGEMENTS BEFORE DEPARTURE

B1.1 We hope and expect to be able to provide you with all the services we have confirmed to you in our Confirmation Invoice and/ or ATOL Certificate. On occasions changes do have to be made (for example due to river conditions such as high or low water levels, lock closures, local mooring restrictions or adverse weather conditions) and we reserve the right to make these. Most of these changes are minor.

However, if we consider them a "Significant Change" we will endeavour to advise you or your Travel Agent as soon as reasonably possible. A Significant Change includes, purely by way of example, a change of accommodation to that of a lower category and/ or price, a change of flight or rail times of more than 12 hours, a change of UK departure location, or a significant change of destination or cruise itinerary. Where, due to circumstances beyond our reasonable control, any vessel is unable to dock at a particular port detailed in any itinerary but an alternative port of call is provided, we will not ordinarily treat this as a Significant Change and the provisions of this clause B1 will not apply.

In accordance with EU regulations we are required to advise you of the actual air carrier operating your flight/ connecting flight/transfer. We do this by listing carriers to be used or likely to be used on the relevant brochure pages and/ or on our website and/ or on your Confirmation Invoice and/ or your ATOL Certificate. Where your Confirmation Invoice or ATOL Certificate indicates that flight tickets have not yet been assigned, we will notify you of the actual flights and carrier as soon as the flights have been assigned. Any changes to the actual airline after you have received your tickets will be notified to you as soon as possible and in all cases at check-in or at the boarding gate. Such a change is deemed to be a minor change.

B1.2 Save where clause H1 applies, if we have to make a Significant Change before your departure we will endeavour to contact you as soon as possible to advise you of any change and we will, if possible, provide you with three alternatives:

B1.2.1 alternative travel arrangements of equivalent or of very closely similar standard and price, if available; or

B1.2.2 alternative travel arrangements of a lower standard together with a refund of the difference in price; or

B1.2.3 cancel your travel arrangements with a full refund of all monies paid.

In all 3 cases, compensation will be paid as detailed in clause D1 below unless the change occurs as a result of circumstances beyond our control where clauses E1 and H1 will apply.

B2. IF WE CANCEL YOUR TRAVEL ARRANGEMENTS

B2.1 In the unlikely event we need to cancel your travel arrangements we will tell you or your Travel Agent as soon as possible. However we will not cancel your travel arrangements less than 14 days before departure unless it is for a reason outside our control as provided in clause H1. If we have to cancel your travel arrangements we will provide you with three alternatives:

B2.1.1 alternative travel arrangements of equivalent or of very closely similar standard and price, if available; or

B2.1.2 alternative travel arrangements of a lower standard together with a refund of the difference in price; or

B2.1.3 cancel your travel arrangements with a full refund of all monies paid.

In all 3 cases, compensation will be paid as detailed in clause D1 below unless the change occurs as a result of circumstances beyond our control (in which case clauses E1 and H1 will apply) or we cancel as a result of your failure to pay your deposit or the balance or any other sum when due or where clause B2.2 applies.

BOOKING CONDITIONS

B2.2 We regret that some travel packages shown on our website or in our brochures can only be operated if a sufficient number of people book them. We will advise you at the time of booking if any travel arrangements are dependent on there being sufficient demand. If there is insufficient demand, we have the right to cancel the travel arrangements in question. If we have to do so, we promise we will tell you no later than 20 days prior to departure. In this situation, you will then have the choice of the options shown in clause B2.1 together with the option, if possible, of the same package departing on a different date. Where we cancel for lack of numbers in accordance with this clause B2.2, no compensation or other amounts (for example, the cost of any connected travel arrangements you have made independently) will be payable.

B3. EXERCISE OF OPTIONS

Where, following a Significant Change or a cancellation by us, the options set out in either clause B1.2 or B2.1 are offered, you are expected to advise us within 7 days of being notified (or such longer period as we may specify in such notification) which proposal you wish to accept. If you have not notified us within 7 days (or such longer period as we may have specified) then we will write to you to obtain confirmation of your choice of the options available. If you fail to respond within a further 7 days, we will cancel your travel arrangements and refund all payments made by or on behalf of you.

C. CHANGES AND CANCELLATION BY YOU

C1. IF YOU CHANGE YOUR BOOKING

C1.1 If you want to change your travel arrangements in any way you or your Travel Agent must inform us in writing as soon as possible. We will try to help you, although we cannot guarantee that we will always be able to do this as changes are subject to availability at the time. Please note that typically changes to scheduled flight tickets are very restrictive and may not be possible without having to cancel the original flight and rebooking.

C1.2 Where we can make a change, we will charge for any additional services, facilities, or other items changed, at the price which applies on the day the change is made. In addition, we reserve the right to apply an administration charge of (1) £100 for each person on the booking where the request for change is made more than 30 days prior to departure and (2) £200 for each person on the booking in any other case together with, in each case, any further costs we incur, for example with our suppliers, in making any change.

C1.3 Any booking discount you may have received at the time your original booking was made may be altered or reduced whenever changes are made if such discount has since been altered, reduced or withdrawn.

C1.4 If you have paid supplements for accommodation and the number of people in your accommodation changes, you may have to pay extra. In addition you may lose any free group places.

C1.5 Any change to your departure date, airport, transport, destination, accommodation, or length of travel has to apply to all members of your booking.

C1.6 You may not change travel arrangements chosen from our brochures or websites to special offer packages such as those featured in any promotional publications, without incurring cancellation charges. Such a change would necessitate the cancellation of your existing arrangements (and be subject to our cancellation charges shown in clause D1) and the re-booking of new arrangements at the price applying on the day the booking is made.

C1.7 Any special offers, savings or promotions may not be combined with other special offers, savings or promotions.

C1.8 It is not usually possible to alter or cancel any travel insurance you may have obtained and your premium will not be refunded, as cover under the policy will already have begun once the policy has been purchased.

C2. IF YOU CANCEL YOUR BOOKING

C2.1 If you wish to cancel all or part of your booking, you or your Travel Agent must write to us. If some or all of your party cancel their booking, we are entitled to treat your booking as

cancelled in accordance with these Booking Conditions, we will levy a cancellation charge as provided in clause D1. These charges are based on the estimated cost of cancelling your arrangements and the reasonable expenses and losses we are likely to suffer if we cannot resell the package.

C2.2 If the reason for your cancellation falls within your insurance cover, you may be able to claim a refund of your cancellation charges from the insurance company less any applicable excess.

C2.3 If you or anyone included within your booking is unable to go for any reason or decides that he/she does not want to travel, you may transfer the whole booking or the place on the booking of the person(s) concerned to someone else/other people suggested by you and acceptable to us subject to the following:

C2.3.1 You must write to us with full details of who cannot or does not want to travel and who you would like to go instead. We must receive this information at least 7 days before departure;

C2.3.2 If the change can be made, you will have to pay any reasonable costs we incur or are asked to pay in order to make the change;

C2.3.3 Anyone who travels in place of anyone who was originally due to travel must agree to these Booking Conditions and any other requirements which apply to the booking before the change can be finalised. If the full cost of the travel arrangements should have been paid when the change is requested but has not been, this must also be paid before the change can be finalised;

C2.3.4 Scheduled airlines often do not allow any name changes within a certain period prior to departure and generally not at all after flight tickets have been issued. If you want or need to make a name change when an airline will not allow it, you will have to cancel the original flight (which means you will lose all the money you have paid for that flight) and pay the full cost of another flight (which may not be the original flight or at the same cost as the original flight as the airline is entitled to offer the cancelled flight to anyone on a waiting list for it). This is the airline's decision and we have no control over it;

C2.3.5 It will not normally be possible to transfer bookings or places on bookings within the period of 7 days immediately prior to departure without cancelling the original booking (and thereby incurring cancellation charges pursuant to clause D1) and rebooking.

C2.4 The cost of your travel arrangements (provided that it includes a flight) includes an amount (currently £2.50 per person) which we are required to pay to the Air Travel Trust Fund as part of the ATOL Protection Contribution ("the APC Sum"). If you cancel your travel arrangements the APC Sum is not refundable in any circumstances.

C2.5 If any person on the booking cancels and you cannot fill that person's place, you may have to pay additional supplements for your accommodation. For example, you may have to pay single or under-occupancy supplements.

C2.6 If you do cancel, you must still pay any amendment charges, which arose before the cancellation, and any deposits paid for any pre-booked items or services.

C2.7 Subject to clause C2.8, you have the right to cancel your holiday before departure without paying a cancellation charge in the event of unavoidable and extraordinary circumstances occurring at your holiday destination or its immediate vicinity which significantly affects the performance of the holiday or which significantly affects transport arrangements to the destination. In these circumstances we shall provide you with a full refund of the monies you have paid but we will not be liable to pay you any compensation. For the purposes of this clause, examples of "unavoidable and extraordinary circumstances" include warfare, acts of terrorism, significant risks to human health such as the outbreak of serious disease at the travel destination or natural disasters such as floods, earthquakes or weather conditions which make it impossible to travel safely to your destination.

C2.8 The right to cancel in clause C2.7 applies where the relevant unavoidable and extraordinary circumstances are or are reasonably likely to commence or continue during

the period of your booked holiday. In the circumstances Viking's standard policy is that the right to cancel may not be exercised more than 30 days prior to your booked holiday commencing.

D. CHANGES, COMPENSATION AND DELAYS

D1. CHANGES AND CANCELLATION CHARGES

The following table sets out the sums payable to us or you in the event of Significant Changes or cancellation. These sums are not payable where we have to make a Significant Change or cancel your travel arrangements as a result of:

(a) matters outside of our control when clauses E1 and H1 shall apply; or

(b) where your booking was accepted "subject to availability" or similar and the travel arrangements are not available. In addition they do not apply where compensation is available under the provisions of clause D2

Period before departure in which notice of cancellation or Significant change is received	Amount you will receive from us if we make a Significant Change	Amount you will receive from us if we cancel	Maximum Cancellation Charge if you cancel
More than 70 days	£10 per person	Return of all monies paid	Deposit only
69-30 days	£20 per person	Return of all monies paid	50% of Total Price
Less than 30 days	£30 per person	Return of all monies paid plus £30 per person	100% of Total Price

The Cancellation Charges payable by you as set out above represent the maximum charges that we are contractually entitled to charge. We consider the reasons for cancellations and the likely level of loss that we are likely to incur on an individual basis. In the circumstances Cancellation Charges that are levied on you (if any) will vary from case to case and be based on our actual financial loss suffered, or likely to be suffered, having first made reasonable attempts to mitigate the same. The nearer the cancellation is to the date of departure, the higher the Cancellation Charges are likely to be as it will be more difficult to resell the cancelled package and any such resale may not be at the original price payable by you.

NOTE: "Total Price" means the total price payable by you for the travel arrangements excluding insurance premiums, flight upgrade charges and any fees payable for any changes made by you to your booking ("Additional Charges"). If you cancel (otherwise than pursuant to clause B) you will continue to be liable for the Additional Charges in addition to the Cancellation Charges set out above.

D2. DENIED BOARDING REGULATIONS & TRANSPORTATION DELAYS

D2.1 If any flight you have booked is cancelled or delayed, your flight ticket is downgraded or boarding is denied by your airline in circumstances which would entitle you to claim compensation against the airline under EC Regulation No 261/2004 – the Denied Boarding Regulations 2004, you must pursue the airline for the compensation due to you. All sums you receive or are entitled to receive from the airline concerned by virtue of these Regulations represent the full amount of your entitlement to compensation or any other payment arising from such cancellation, delay, downgrading or denied boarding. The fact a delay may entitle you to cancel your flight does not automatically entitle you to cancel any other arrangements even where those arrangements have been made in conjunction with your flight. We have no liability to make any payment to you in relation to the Denied Boarding Regulations or in respect of any flight cancellation or delay, downgrading of any flight ticket or denial of any boarding as the full amount of your entitlement to any compensation or other payment (as dealt with above) is covered by the airline's obligations under the Denied Boarding Regulations. If your airline does not comply with these rules you should complain to the Civil Aviation Authority on 0330 022 1500 www.caa.co.uk.

D2.2 Unfortunately, flight or other transport delays sometimes occur. Depending on the length of the delay and

BOOKING CONDITIONS

surrounding circumstances, the carrier concerned should provide refreshments when and where appropriate. We are generally not in a position to provide any assistance in the event of flight or other transportation delays and cannot accept any liability except where expressly stated in these Booking Conditions or as otherwise provided in the Package Travel and Linked Travel Arrangements Regulations 2018.

D3. RIGHTS UNDER PACKAGE TRAVEL AND LINKED TRAVEL ARRANGEMENTS REGULATIONS 2018

D3.1 In accordance with the Regulations, where it is impossible for you to return to your departure point on the return date of your "package" (as defined in the said Regulations) due to "unavoidable and extraordinary circumstances", we shall provide you with the necessary accommodation for a period not exceeding 3 nights per person. Where possible, this accommodation shall be of comparable standard to the accommodation booked by you under the package. For the purposes of this clause, examples of "unavoidable and extraordinary circumstances" include warfare, acts of terrorism, significant risks to human health such as the outbreak of serious disease at the travel destination or natural disasters such as floods, earthquakes or weather conditions which make it impossible to travel safely to the destination.

D3.2 The limitation of costs for 3 nights accommodation referred to above does not apply to persons with reduced mobility as defined by Article 2 of Regulation (EC) 1107/2006, concerning the rights of disabled persons and persons with reduced mobility when travelling by air and any other person accompanying them and pregnant women as well as persons in need of specific medical assistance, provided you have notified us of their needs at least 48 hours prior to start of the package.

E. LIMITATION OF OUR LIABILITY TO YOU

E1. If the contract we have with you is not performed or is improperly performed by us or our suppliers we will pay you appropriate compensation if this has affected the enjoyment of your travel arrangements.

However we will not be liable (and clause H1 will apply) where any failure in the performance of the contract is due to:

E1.1 you; or

E1.2 a third party unconnected with the provision of the travel arrangements and where the failure is unforeseeable or unavoidable; or

E1.3 unusual and unforeseeable circumstances beyond our control, the consequences of which could not have been avoided even if all due care had been exercised; or

E1.4 an event which we or our suppliers, even with all due care, could not foresee or forestall.

E2. In addition to the provisions of clause H1, our liability, except in cases involving death, injury or illness, shall be limited to a maximum of 3 times the cost of your travel arrangements.

E3. Should you or any member of your party suffer illness, personal injury or death attributable to a third party unconnected with the provision of the services, or as a result of failures due to unusual and unforeseeable circumstances beyond our control, the consequences of which could not have been avoided even if all due care had been exercised, or an event which we or our suppliers, even with all due care, could not foresee or forestall, we will offer you such advice, guidance and assistance as is reasonable in the circumstances.

E4. Our liability will also be limited in accordance with and/or in an identical manner to:

E4.1 the contractual terms of the companies that provide the transportation for your travel arrangements which are incorporated into and form part of your contract with us; and

E4.2 any relevant international convention, for example the Montreal Convention in respect of travel by air, the Athens Convention in respect of travel by sea, the Berne Convention in respect of travel by rail and the Paris Convention in respect of the provision of accommodation, which limit the amount

of compensation that you can claim for death, injury, delay to passengers and loss, damage and delay to luggage which are incorporated into and form part of your contract with us and we are to be regarded as having all the benefit of any limitation of compensation contained in these or any other such conventions.

E5. Unless otherwise expressly indicated by us in writing, excursions or other tours that you may choose to book or pay for whilst you are away are not part of the travel arrangements provided by us. For any excursion or other tour that you book, your contract will be with the operator of the excursion or tour and not with us. We are not responsible for the provision of the excursion or tour or for anything that happens during the course of its provision by the operator. Where an excursion or other tour is booked through us no refund will be available in the event of you subsequently being unable or choosing not to take part. This clause E5 applies even where a Viking representative accompanies the tour or excursion.

E6. Where you have booked a "Cruise Only" holiday, we cannot accept any liability for the costs of flights or other travel arrangements in the event of changes being made to the scheduled departure or arrival times or locations of the cruise vessel.

E7. The provisions of clauses E1 to E6 inclusive are in addition to any other limitation of liability contained in these Booking Conditions.

E8. Nothing in these Booking Conditions affect any statutory rights that you may have under the relevant jurisdiction applicable pursuant to clause H8 (including any rights under the Package Travel and Linked Travel Arrangements Regulations 2018).

F. YOUR RESPONSIBILITIES

F1. SPECIAL REQUESTS

If you have a special request, we will do our best to help, but we cannot guarantee it except as set out below. Please advise your Travel Agent or us (if booking direct) of your request at the time of booking and make sure that we are given as much detail as possible. If your special request is vital to your travel arrangements, it must be specifically agreed with us before or at the time you book. We promise to comply with any special request which we have specifically agreed and confirmed in writing. General confirmation that a special request has been noted or passed on to the supplier or the inclusion of a special request on your Confirmation Invoice or on the acknowledgement of your booking or any other documentation is not confirmation that the request will be met. Unless and until specifically confirmed in writing all special requests are subject to availability. If any additional cost is applicable, it will either be invoiced to you prior to your departure or should be paid for locally.

F2. YOUR DOCUMENTATION

F2.1 You are responsible for ensuring that you and all other persons included in the booking satisfy all passport, visa, travel insurance and health certificate requirements and we accept no responsibility for any refusal of travel or entry into any destination or for any liabilities, losses, delays or expenses incurred through any irregularity in such documentation. If you have any queries with regard to documentation and insurance requirements you must raise them with us or your Travel Agent well in advance of travel commencing. In the event we are asked to re-issue tickets that have been lost, destroyed or stolen and we agree to do so, any charges incurred as a result of this will be payable by you.

F2.2 Many of the airlines that provide the flight element of the arrangements we sell impose fines and costs on us if any passengers who have booked with us do not have the necessary travel or other documents for the countries they are visiting or passing through, even where this occurs through no fault of ours. In this situation we have no choice but to pass on to you all fines, costs, surcharges, financial penalties and other sums of any description which are imposed on or incurred by us. You will be responsible for reimbursing us accordingly in full.

F3. HEALTH PRECAUTIONS, PREGNANCY, DISABILITIES & FCDO ADVICE

F3.1 You are solely responsible for checking what vaccinations and other health precautions are required or are advisable for your chosen destination and journey with your doctor in good time before departure. You and each member of your group are responsible for ensuring that you have had all relevant vaccinations and are otherwise fit to travel. If you have any doubts or require any information then you must contact well in advance of travel commencing. Please note that whilst we will endeavour to assist anyone who becomes ill whilst on board any vessel, any health care facilities are limited and we cannot be expected to provide any inoculations or specialist health care whilst on board.

F3.2 Individual airline policies differ in respect of air travel when pregnant. In addition, given the nature of our ocean cruises and the facilities available on board, we do not allow passengers to embark the vessel where they are more than six months pregnant. If you or any member of your group is or becomes pregnant prior to the start of your travel arrangements, then you must inform us immediately so that we can advise whether or not travel will be possible and, if so, what arrangements may need to be put in place and/or what medical confirmation of fitness to travel may be required. We cannot be responsible for any losses suffered where we are not informed of any pregnancy well in advance of departure and/or if any airline refuses to accept you or any member of your party as a passenger for reasons of pregnancy.

F3.3 You must provide us with full details of any existing dietary requirements, medical problem or disability or other special needs (including impaired mobility or the need to use any wheelchair, mobility scooter or walking frame) that may affect your travel arrangements (including, in particular, any accommodation requirements) at the time of booking. If in our reasonable opinion, your chosen travel arrangements are not suitable for your medical problem or disability or other special need or you are not travelling with someone who can provide all assistance you may reasonably require, we have the right to refuse to accept the booking. If you do not give us full details of your medical problem or disability or other special need at the time of booking, we can also cancel the booking when we find out the full details if in our reasonable opinion the travel arrangements are not suitable or you are not travelling with someone who can provide all assistance reasonably required. If we cancel in this situation, cancellation charges as set out in clause D1 must be paid by the person concerned. Please also note the additional requirements and information set out in clause H10 that apply in respect of our Expedition Cruises. For further information please also see our advice section for Passengers with Health Issues, Disabilities, Impaired Mobility or Other Special Needs at the end of these Booking Conditions and/or contact our Guest Services team on 020 8780 7900 or 0800 319 66 60.

F3.4 We reserve the right to deny embarkation or remove any person from a vessel or optional shore excursion who in our reasonable opinion or in the opinion of the vessel's Master is not fit to travel, and/or has not received written confirmation from us that reasonable adjustments can be made to cater for any particular requirements. In such cases, all related expenses, (including those incurred by the relevant person, or anyone travelling with him or her, in returning home) will be borne by the relevant passengers and they shall not be entitled to any refund or any other compensation whatsoever and we shall have no further liability to them. In addition, we may disembark at any port any passenger who may be suffering from any contagious or infectious disease or whose presence, in the opinion of the vessel Master, may be detrimental to the comfort or safety of other passengers or the crew, or who, in the vessel Master's opinion, might be excluded from landing at any destination by Immigration or other Governmental Authorities.

F3.5 We reserve the right at any time (including after departure) to introduce additional health and safety policies and procedures to control the risk of the spread of any infectious disease. Please note that this may include a requirement that passengers have had appropriate vaccinations prior to embarkation and/or agree to submit to regular testing for symptoms and/or agree to isolate

BOOKING CONDITIONS

themselves whilst on board. Failure to adhere to such health and safety policies and procedures may result in you being denied embarkation or being required to disembark and we shall be entitled to treat such failure to adhere to our policies and procedures as a cancellation of your booking and no compensation or other refund shall be payable. We will endeavour to provide as much notice as possible of any additional health and safety policies and procedures that may need to be introduced but, in certain circumstances, this may not always be possible. Please also note that any health and safety policies and procedures introduced will be in addition to any requirements imposed by ports that are visited during the cruise.

F3.6 The Foreign, Commonwealth & Development Office ("FCDO") produces a wide range of material about overseas countries including details of political unrest, crime and health issues. If you have any particular concerns then you should refer to the FCDO website at <https://www.gov.uk/government/organisations/foreign-commonwealth-development-office>.

F4. INSURANCE

F4.1 You must take out insurance suitable for your needs before you travel. We cannot be held responsible for any costs you incur as a result of failing to do so.

F4.2 If you participate in sports and activities whilst travelling that have been organised and arranged independently of us, it should be understood that participation is at the individual's own risk and it is your responsibility to obtain the relevant insurance.

F4.3 UK residents or citizens must be aware that following the UK's departure from the EU, the European Health Insurance Card (EHIC) will, or may, no longer cover UK residents or citizens whilst travelling within the EU. In the circumstances, if UK residents or citizens travel without separate travel insurance (as required by F4.1), they will be responsible for all associated medical, hospitalisation, repatriation and other costs incurred as a result of illness or accident whilst travelling in the EU.

F4.4 In respect of our additional insurance requirements relating to Expedition Cruises, please see clause H10.

F5. BEHAVIOUR

F5.1 You must be responsible for the behaviour of yourself and your party and must at all times ensure that you and your party comply with the vessel's rules and regulations, any orders and directions of the vessel's Master, officers and medical staff (as applicable) and that your conduct will not impair the safety of the vessel or jeopardise or inconvenience other passengers. We can refuse to accept you as a customer or refuse to continue dealing with you and/or any other member of your party by terminating your travel arrangements if behaviour is, or is likely to be, in our reasonable opinion, or in the opinion of any airline pilot, vessel Master or other person in authority, disruptive, upsetting or dangerous to yourself or anyone else or if you or any member of your party have caused or are likely to cause damage to property. We will not pay any refund, compensation or other sum whatsoever or any costs or expenses incurred by you if we have to terminate your travel arrangements due to such unacceptable behaviour. In this situation we will then have no further responsibility for you or any other member of your party (including any return travel arrangements). If your unacceptable behaviour means you are not allowed to board your outward flight we will treat your booking as cancelled from that moment and you will have to pay cancellation charges (see clause D1).

F5.2 With regard to any flights and/or cruises that form part of your travel arrangements the airline captain or vessel Master (as applicable) has authority over the aircraft/vessel and passengers at all times when they are boarding or on board. He/ she may prevent you or any member of your party from travelling if you or such member are considered unfit to do so, or if you or such member pose a danger to the aircraft/vessel or passengers. In such circumstances we shall seek compensation from you for any losses caused by your behaviour or by the behaviour of any member of your party (e.g. the cost of diverting an aircraft or vessel). Disruption on board an aircraft or vessel is a criminal offence, and you may be prosecuted. If you are refused carriage on an aircraft because of your

disruptive behaviour, or you are under the influence of alcohol or drugs, your airline may pass on your details and the date of the refusal of carriage to other airlines for their information. This in turn may make it difficult for you or others in your party to book other airline tickets.

F6. ASSISTANCE IF YOU GET INTO DIFFICULTIES

If you or any member of your party suffers during the course of your holiday any difficulty as a result of any activity which does or does not form part of your contracted travel arrangements, we will offer you prompt assistance without undue delay. Such assistance may include assisting you in making communications and helping you find alternative travel arrangements. If the difficulty is caused intentionally by you or as a result of your negligence, we may charge a reasonable fee for that assistance which will not exceed the actual cost incurred by us. All assistance (financial or otherwise) is subject to our reasonable discretion and subject to you notifying us promptly of your need. If you are entitled to have any costs and expenses arising from such an incident met by or from an insurance policy or if you recover any costs and expenses relating to the incident from a third party you must repay us for costs and expenses we have incurred in assisting you.

F7. ALCOHOL POLICY

Please note that you must be aged 21 or over in order to purchase or consume alcoholic beverages whilst on board our vessels. Silver Spirit packages (or similar arrangements for the supply of alcohol on board) can only be purchased where both occupants of the relevant cabin or stateroom are over the age of 21 and each occupant must purchase the relevant package for the full duration of the cruise. Proof of age may be required at any time and breach of this policy may result in persons involved (whether in the purchase, supply or consumption) being removed from the vessel pursuant to the provisions of clause F5.

G. IF YOU HAVE A COMPLAINT

G1. If you have cause for complaint whilst travelling, you must bring it to the attention of the Viking representative on board the cruise vessel or at your hotel. If your complaint is not resolved locally, please follow this up within 28 days of your return home by writing to our Guest Services team at Viking, Nelsons House, 83 Wimbledon Park Side London SW19 5LP or by email to customerservices@viking.com giving your booking reference and all other relevant information. Please keep your letter/email concise and to the point. This will assist us to quickly identify your concerns and speed up our response to you. It is strongly recommended that you communicate any complaint to the supplier of the services in question as well as to our representative without delay and complete a report whilst on board or at the relevant hotel. If you fail to follow this simple procedure we will have been deprived of the opportunity to investigate and rectify your complaint whilst you are on board and this may affect your rights under this contract.

G2. We are a member of ABTA, membership number V924X and are obliged to maintain a high standard of service by ABTA's Code of Conduct. We certainly hope that we can settle any complaints amicably. However, should this prove not to be the case you may refer any dispute to arbitration through ABTA's arbitration scheme. The scheme provides for a simple and inexpensive method of arbitration on documents alone with restricted liability for you in respect of costs. The scheme is subject to certain financial limits on the amount that can be claimed as determined from time to time by ABTA. Please note that the scheme does not apply to claims which are solely in respect of physical injury or illness or their consequences, although claims which include an element of minor injury or illness can be considered subject to a limit as set from time to time by ABTA on the amount the arbitrator can award per person, in respect of this element.

G3. Any application for arbitration under clause G2, together with any related statement of claim, must be received by ABTA within eighteen months of the date of return. Outside this time limit arbitration under the scheme may still be available if we agree, but the ABTA Code does not require such agreement. For injury and illness claims, you may like to use the ABTA/ Chartered Institute of Arbitrators Mediation Procedure. This is a voluntary scheme

and requires us to agree for mediation to go ahead. The aim is to help you resolve your dispute in a quick and cost effective way. Details are available on request or from www.abta.com.

H. MISCELLANEOUS

H1. CHANGES DUE TO CIRCUMSTANCES BEYOND OUR CONTROL

We will not be liable to pay any compensation if we are forced to cancel or in any way change your travel arrangements as a result of unusual or unforeseeable circumstances beyond our control, the consequences of which could not have been avoided even with all due care. These include unavoidable technical problems with transport, changes imposed by rescheduling

or cancellation of flights by an airline or main charterer, the alteration of the airline or aircraft type, changes imposed by rescheduling or cancellation of rail travel by the relevant operator, war or threat of war, civil strife, industrial disputes, natural disaster, adverse weather, epidemic or terrorist activity.

H2. YOUR FINANCIAL PROTECTION

H2.1 When you buy an ATOL protected flight or flight inclusive holiday from us you will receive an ATOL Certificate. This lists the flight accommodation car hire and/or other services that are financially protected, where you can get information on what this means for you and who to contact if things go wrong.

H2.2 We, or the suppliers identified on your ATOL certificate, will provide you with the services listed on the ATOL Certificate (or a suitable alternative). In some cases, where neither we nor the supplier are able to do so due to reasons of insolvency, an alternative ATOL holder may provide you with the services you have bought, or a suitable alternative (at no extra cost to you). You agree to accept that in those circumstances, the alternative ATOL holder will perform those obligations and you agree to pay any money outstanding to be paid by you under your contract to that alternative ATOL holder. However you also agree that in some cases it will not be possible to appoint an alternative ATOL holder, in which case you will be entitled to make a claim under the ATOL scheme (or your credit card issuer where applicable).

H2.3 If we, or the suppliers identified on your ATOL certificate, are unable to provide the services listed (or a suitable alternative, through an alternative ATOL holder or otherwise) for reasons of insolvency, the Trustees of the Air Travel Trust may make a payment to (or confer a benefit on) you under the ATOL scheme. You agree that in return for such a payment or benefit you assign absolutely to those Trustees any claims which you have or may have arising out of or relating to the non-provision of the services, including any claim against us, the travel agent (or your credit card issuer where applicable). You also agree that any such claims may be re-assigned to another body, if that other body has paid sums you have claimed under the ATOL scheme.

H2.4 We are also a member of ABTA (ABTA number V924X). If your travel arrangements do not include flights, ABTA will financially protect your travel arrangements in the same way except that, if already abroad, you will be returned to the point where your contracted arrangements with us commenced. Please go to www.abta.com for a copy of the guide to ABTA's scheme of Financial Protection.

For further information about ABTA, the Code of Conduct and the arbitration scheme available to you if you have a complaint (see clause G), contact Consumer Affairs, ABTA, 30 Park Street, London SE1 9EQ tel 0203 117 0599 or www.abta.com.

H3. DATA PROTECTION

Information about you and members of your party, including your names, contact details and any special needs, disabilities or dietary requirements is collected by us when you request information or make a booking with us. We may disclose this information to our service providers (who may be located outside the UK/EEA) for the purpose of providing you with your travel arrangements. Only information necessary for this purpose will be disclosed to them.

BOOKING CONDITIONS

In the case of air travel, it may be mandatory for us to disclose information for security and anti-terrorism purposes and any other purpose imposed on us by governments or airlines. We may use your information for the purposes set out in our data protection registration with the Office of the Information Commissioner. We may disclose the same to companies who act as data processors on our behalf. Some information, for example relating to your religion or health, may be "special category data" within the meaning of the Data Protection Act 2018. We need this information to cater for your needs, but it is collected on condition that we have your positive consent. If you do not agree to our use of your information, we cannot accept your booking.

By making a booking with us, you agree to allow your insurers, their agents and medical staff to disclose relevant information to us in circumstances where we may need to act in the interests of everyone in the group with whom you are travelling. For example, if you contract an infectious illness whilst travelling, we may need to make special arrangements for you and ensure that you do not return with the group immediately.

For further information about how we process and protect your data please see our Privacy Notice which is available on our website or which can be obtained by contacting our Guest Services team at Viking, Nelsons House, 83 Wimbledon Park Side London SW19 5LP or by telephone on 020 8780 7900. Please note that we reserve the right to change the terms of our Privacy Notice from time to time and that the Privacy Notice does not form part of these Booking Conditions.

H4. CHILDREN/MINORS

Due to the nature of our cruises, we do not maintain specific facilities or services for children aboard cruise vessels. In the circumstances you and all members of your party must be aged 18 or over on or before the day you are scheduled to embark on the cruise vessel.

H5. SUN DECK ACCESS

During passage through locks or under low bridges or in the case of adverse weather, it may be necessary to close the sun deck for passenger use. In the interest of safety, sun deck closures are rigidly enforced.

H6. MOORING AND DOCKING FACILITIES

In some ports, it is likely that ships will be docked alongside each other. This will result in your view being blocked. You may also need to pass through other vessels when going ashore.

H7. USE DISPLAY OF IMAGES & LIKENESSES

Viking shall have the exclusive right to include photographic, video and other visual portrayals of our guests in any pictorial medium of any nature whatsoever for the purpose of trade, advertising, sales, publicity or otherwise, without compensation to you, and all rights, title and interest therein (including all worldwide copyrights therein) shall be the sole property of Viking, free from any claims by you or any person deriving any rights or interest from you. By boarding the vessel you agree that Viking having the right to use your image in all promotional materials.

Without our express prior written consent, you expressly agree not to use, post, share or upload any photograph, video recording or other visual or audio portrayals (i) of you and/or any other passenger in combination with crew or our vessels, or (ii) that depict any of our vessels, their design or equipment or any part thereof whatsoever, in either case for any commercial purpose or in any media broadcast or for any other non-private use. For the avoidance of doubt, you are permitted to use, portrayals of you and/or any other Passenger in combination with crew or the Ship for your private noncommercial use.

H8. JURISDICTION/GOVERNING LAW

We both agree that any dispute, claim or other matter of any description (and whether involving personal injury or not) which arises out of or in connection with your booking or travel must be dealt with under the ABTA Arbitration Scheme or brought in the Courts of England and Wales only (unless you are a resident of Scotland or Northern Ireland in which

case any proceedings must be brought in either the Courts of your own country or those of England and Wales). We both also agree that English law (and no other) will apply to your contract (unless proceedings are brought in Scotland or Northern Ireland, in which case Scottish or Northern Irish law, as applicable, will apply instead). If this provision is not acceptable to you, you must tell us at the time of booking.

H9. CONDITIONS OF CARRIAGE

When you travel by air, rail or by sea, your journey may be subject to certain international conventions such as the Warsaw Convention, Montreal Convention the Berne Convention or Athens convention. You agree that the transport company's own Conditions of Carriage will apply to you on that journey. When arranging this transportation for you, we rely on the terms and conditions contained within these international conventions and those 'Conditions of Carriage'. You acknowledge that all of these terms and conditions form part of your contract with us as well as the transport company. You can ask us to provide you with a copy of any of the conditions applicable to your journey. These may limit or exclude liability, especially in respect of lost or delayed baggage.

H10. ADDITIONAL PROVISION RELATING TO CRUISES MARKETED AS "EXPEDITION CRUISES"

In this clause H10, the terms:

"Expedition Cruise" means those cruises marketed by us as "Viking Expedition Cruises" which cruises may involve travel to remote locales, including, but not limited to, the Arctic or Antarctic regions.

"Fit to Travel Letter" means a personal medical questionnaire to be completed by both the Passenger and a qualified medical advisor in a form as prescribed by us and which will be required to be submitted to us (including any updates in respect of the same) prior to you be permitted to travel.

H10.1 INSURANCE

10.1.1 Save where clause H10.1.3 applies, we require all passengers to provide written evidence, prior to departure, that they have in place suitable insurance cover that will cover emergency medical treatment, evacuation and repatriation from the areas to be visited by the relevant cruise. Such cover for emergency medical treatment, evacuation and repatriation must have a limit of indemnity of not less than £250,000, or such alternative level as we may reasonably require. Proof that such insurance cover is on risk will normally be required to be produced to us not less than 12 months prior to the date of departure or, if departure is due less than 12 months after booking, then prior to your booking being confirmed. If you advise us at least 12 months prior to departure that insurance cannot be obtained for you or any member of your group purely on medical or disability grounds, then, unless clauses H10.1.3 applies, you may cancel your booking (but unless otherwise agreed by us so far only as it relates to the relevant individual who is unable to obtain cover) and receive a refund of monies paid in respect of such individual.

10.1.2 You must advise us without delay of any withdrawal of insurance cover (or any circumstances that can reasonably be expected to result in such withdrawal or the policy otherwise being avoided by the insurers) that occurs prior to departure. Immediately prior to departure we may require evidence that insurance cover as required under clause H10.1.1 remains in force and if evidence cannot be produced then, unless clause H10.1.3 applies, we may cancel the booking (whether in total or just in respect of the relevant individual) in which case Cancellation Charges may be levied under clause D1.

10.1.3 We may, in our reasonable discretion, waive the requirements in clauses H10.1.1 and H10.1.2 but such waiver is only likely to be given where an individual who is unable to obtain the required insurance cover is able to provide evidence of alternative financial security that will cover, in full, the reasonably foreseeable costs of emergency medical treatment, evacuation and repatriation. Instances of a waiver of the above conditions are likely to be rare and passengers should discuss individual circumstances with us as soon as they become aware of the same as, if insurance cover is unavailable,

it is likely that the relevant passenger should not be travelling on an Expedition Cruise.

10.1.4 Where we intend to cancel an individual's booking under this clause H10 you will be given the opportunity to transfer that individual's place on the booking to someone else suggested by you and clause C2.3 shall apply in respect of any such transfer. Please note where an individual's booking is cancelled under this clause H10 and you cannot fill that person's place, you may have to pay additional monies by way of single or under-occupancy supplements.

H10.2 ACKNOWLEDGMENT OF INCREASED RISKS

By making a booking with us for an Expedition Cruise you and all members of your group acknowledge that:-

(1) the nature of the cruise is such that it comes with additional risks and dangers above and beyond those of other more mainstream cruises, such as, by way of example only, a greater likelihood that you will be exposed to extreme weather conditions or other unpredictable forces of nature (including the behaviour of animals), a greater likelihood that you will be required to exert yourself physically or psychologically, that you will travel to remote regions far from medical services (including regions where it is difficult or even impossible to carry out medical evacuations by helicopter or other means), and that equipment may malfunction in remote locations;

(2) you recognise the increased risks of travelling on an Expedition Cruise and the increased possibility of injury to yourself or your property, and the resulting consequences;

(3) the reason, at least in part, of your travel on an Expedition Cruise is because of the excitement and enjoyment provided on Expedition Cruises resulting from, at least in part, the increased risks inherent in an Expedition Cruise;

(4) Expedition Cruises may not be able to offer the same services and accommodation standards as other more mainstream cruises and that you may be subject to greater restrictions on what you may bring on board; and

(5) the pricing of your ticket for an Expedition Cruise is based on your assumption of the inherent increased risks of an Expedition Cruise.

H10.3 FITNESS TO TRAVEL

By making a booking with us for an Expedition Cruise you and all members of your group acknowledge that:-

(1) embarkation on the vessel will constitute a warranty from each passenger that, save as may have already been disclosed to us in writing, he or she has no physical or psychological condition which entails an unreasonable increased risk to the health or safety of persons on board or to the conduct of the Expedition Cruise;

(2) if we become aware of any such condition, we may cancel the booking or deny boarding (whether in total or just in respect of the relevant individual and including denial of boarding at any port) in which case Cancellation Charges may be levied under clause D1;

(3) in order to travel on an Expedition Cruise, you and all members of your group will be required to (i) provide to us a Fit to Travel Letter approximately 6 months prior to departure (or immediately after booking if you book travel on an Expedition Cruise within 6 months prior to departure); (ii) inform us in writing of any changes to the answers to any items on the Fit to Travel Letter at least 30 days before departure and also at the point of embarkation, and (iii) alert us immediately after you become aware of any changes to any answers to any items on the Fit to Travel Letter after embarkation;

(4) we are not medical advisors and that, notwithstanding the provision to us of any medical information relevant to an Expedition Cruise and/ or you being allowed to embark, such does not constitute any medical advice from us as to the advisability or safety of you participating in an Expedition Cruise or any activities related to an Expedition Cruise; and

(5) you and each member of your group must rely solely on the advice of his or her medical practitioner as to the advisability or safety of participating in an Expedition Cruise or any activities related to an Expedition Cruise.

BOOKING CONDITIONS

YOUR KEY RIGHTS UNDER THE PACKAGE TRAVEL AND LINKED TRAVEL ARRANGEMENTS REGULATIONS 2018

General

The combination of travel services offered to you is a package within the meaning of the Package Travel and Linked Travel Arrangements Regulations 2018.

Therefore you will benefit from all EU rights applying to the packages. Viking River Cruises UK Limited will be fully responsible for the proper performance of the package as a whole.

Additionally, as required by law, Viking River Cruises UK Limited has protection in place to refund your payments and, where transport is included in the package, to ensure your repatriation in the event that it becomes insolvent.

Key Rights

- Travellers will receive all essential information about the package before concluding the package travel contract.
- There is always at least one trader who is liable for the proper performance of all the travel services included in the contract.
- Travellers are given an emergency telephone number or details of a contact point where they can get in touch with the organiser or the travel agent.
- Travellers may transfer the package to another person, on reasonable notice and possibly subject to additional costs.
- Travellers may terminate the contract without paying any termination fee and get a full refund of any payments if any of the essential elements of the package, other than the price, has changed significantly. If before the start of the package the trader responsible for the package cancels the package, travellers are entitled to a refund and compensation where appropriate.
- Travellers may terminate the contract without paying any termination fee before the start of the package in the event of exceptional circumstances, for instance if there are serious security problems at the destination which are likely to affect the package.
- Additionally, travellers may at any time before the start of the package terminate the contract in return for an appropriate and justifiable termination fee.
- If, after the start of the package, significant elements of the package cannot be provided as agreed, suitable alternative arrangements will have to be offered to the traveller at no extra cost. Travellers may terminate the contract without paying any termination fee, where services are not performed in accordance with the contract and this substantially affects the performance of the package and the organiser fails to remedy the problem.
- Travellers are also entitled to a price reduction or compensation for damages or both where the travel services are not performed or are improperly performed.
- The organiser has to provide assistance if the traveller is in difficulty.
- If the organiser or the retailer becomes insolvent, payments will be refunded. If the organiser or, where applicable, the retailer becomes insolvent after the start of the package and if transport is included in the package, repatriation of the travellers is secured. Viking River Cruises UK Limited has taken out insolvency protection with the following entities:

For flight inclusive holidays: Civil Aviation Authority of Aviation House, Beehive Ringroad, Crawley, West Sussex RH6 0YR, www.caa.co.uk, telephone: 0330 022 1500, email: claims@caa.co.uk

For package holidays that do not include a flight: ABTA – the Travel Association at 30 Park Street, London SE1 9EQ, www.abta.com, telephone: 0203 758 8779, email: customerprotection@abta.co.uk

THE PACKAGE TRAVEL AND LINKED TRAVEL ARRANGEMENTS REGULATIONS 2018:

Can be found at: www.legislation.gov.uk/uksi/2018/634/contents/made

ADVICE FOR PASSENGERS WITH HEALTH ISSUE, DISABILITIES, IMPAIRED MOBILITY OR OTHER SPECIAL NEEDS

At Viking we want all our passengers to have a safe and enjoyable cruise. Whilst we will always look to make reasonable adjustments for those with specific dietary requirements, health issues, disabilities, impaired mobility or other special needs that may affect their fitness to travel, or ability to make full use of our on board facilities or undertake shore excursions, we are reliant on passengers informing us well in advance of any such matters.

We must be provided with full details of any such issues, including details of those travelling with the relevant passenger who can provide assistance, prior to booking so that we can advise the relevant passenger whether or not the relevant cruise will be suitable and/or whether reasonable adjustments can be made.

Where such issues arise after your booking has been made we must be advised immediately so that we can establish whether or not any reasonable adjustments are required and can be made such that the relevant booking can proceed.

Please note we cannot guarantee that we will always be able to accommodate any required adjustments as any adjustments will be dependent on the particular cruise vessel and the proposed destinations.

Passengers need to be aware that there are inherent risks associated with travelling aboard ships that are unique to cruise tour travel.

For people who are ill, or have a disability or impairment, the risks can be more significant. Guests must normally be able to independently move around the ship in case of an emergency, rough seas, deal with the lack of immediate access to medical services in certain parts of the world, and acknowledge that access to some areas of the ship and ports of call may be limited or impossible. We must reserve the right to determine whether a guest is fit to travel, and to deny boarding or require disembarkation in the event that a guest represents a risk to themselves or to the safety and wellbeing of those on board the ship. The decision of the ship's Master shall be final in respect of such decisions.

Accessibility and Special Needs

Where passengers have any mobility or other special needs please contact our Guest Services team on 020 8780 7900. We may require the completion of a medical or accessibility form by you and/or your doctor to establish the full extent of your likely needs and the extent to which you may require medical or other assistance during the cruise.

If a passenger requires the use of a wheelchair or other mobility equipment, normally this must not exceed 22" in width. Passenger must bring and be solely responsible for all necessary items related to any medical condition or mobility challenge.

Airport, Port & Excursion Accessibility and Limitation

Some ports of call may have physical conditions which may preclude certain passengers from going ashore. Additionally, for cruise tours in China, on the Mekong River, in Egypt, in Ukraine and for other destinations not specifically noted, certain additional conditions, restrictions and limitations exist on board, at the ports, during excursions and on land that are beyond Viking's control.

Ship and airport access in these and other regions, including lack of wheelchair, walker or scooter accessibility, extended periods of standing and steps, are inherently present in tours that may not be appropriate for guests with certain medical conditions and/or physical impairments.

Airports in certain regions typically do not have ramps or elevators.

Excursions sometimes visit ancient sites with uneven terrain and stairs and may include extended periods of walking over uneven surfaces. Guests using wheelchairs, scooters, walkers, crutches, or other mobility aids or who may need physical assistance throughout the trip should consider these needs when making a booking as our onboard personnel are not required to perform personal tasks or assist with eating, dressing, toileting, lifting or pushing a wheelchair.

Motorized scooters typically cannot be taken on board planes in certain regions because authorities such as the China Aviation Administration forbid any battery of capacity greater than 160Wh (most scooter batteries) on board an aircraft. Additionally, lithium batteries cannot be placed in checked baggage and must be hand-carried as on board carry-on. All batteries must have the capacity clearly printed on the outside or they will not be allowed to be on board. To calculate your battery capacity if it is only marked in mAh, divide the mAh number by 1000 and multiply by 3.7. For example, a capacity of 10400mAh./1000=10.4Ahx 3.7v=28.48 Wh (under the limit of 160Wh).

Ship Access

Due to the nature of some ships (including cabin sizes), certain cruise tours are not appropriate for travellers who use wheelchairs, walkers or scooters. To embark/disembark from the ship, guests may have to walk down/up steps and ramps without a walker or wheelchair, as gangways/ramps may not be wide enough to accommodate these items.

Not all ships have elevators, and some have split-level decks and/or significant thresholds. Please note that personnel are not required to lift guests or push wheelchairs.

Potential guests with any mobility or other special needs should review their proposed ship's layout on our website and consider their needs when making a booking.

Denial of Embarkation and Right to Require Removal

Please note that in accordance with our Booking Conditions, we reserve the right to deny embarkation or remove any person from a ship or optional shore excursion who in our reasonable opinion or in the opinion of the ship's Master is not fit to travel and/or has not received written confirmation from us that reasonable adjustments can be made to cater for any particular accessibility requirements.

In such cases, all related expenses, (including those incurred whether by the relevant person or anyone travelling with him or her in returning home) will be borne by the relevant passengers and they shall not be entitled to any refund or any other compensation whatsoever and we shall have no further liability to them.

PRIVACY NOTICE

Viking River Cruises UK Limited (the "Company", "We", "Us" or "Our") is committed to respecting and protecting Your privacy. This Privacy Notice is provided for our prospective, existing and former customers ("You", "Your").

This Privacy Notice (together with Our Cookie Notice published on our Website, and the terms of use published at www.viking.com/legal) (the "Notices") tells You about how We process your personal data, including Our collection, usage and sharing of Your personal data, and including in relation to Your use of our website at viking.com (the "Website").

We will only process Your personal data in accordance with the Notices (and any other information we give to you about how we process Your personal data), and in accordance with the Data Protection Legislation.

In this Privacy Notice the terms "personal data", "Data Controller", "Data Processor" each have a special meaning that is set by legislation (the "Data Protection Legislation"). The Data Protection Legislation is: the Data Protection Act 2018 and the EU General Data Protection Regulation (2016/679) as applied in English law ("GDPR").

YOUR DATA CONTROLLER

We are a Data Controller in relation to Your personal data. Our address is Viking, Nelsons House, 83 Wimbledon Park Side, London SW19 5LP.

The Company may be contacted by email at data.protection@viking.com and by telephone on 0800 458 69 00.

DATA PROTECTION OFFICER

Our Data Protection Officer can be contacted at data.protection@viking.com

BOOKING CONDITIONS

INFORMATION WE COLLECT ABOUT YOU

We obtain Your personal data from the following sources:

Directly from you

You will know what personal data We obtain from You, because You (or someone who You trust, and who You have authorised Us to deal with, such as a member of Your family) provide it to Us. Examples of how We obtain personal data from You include: when You make an enquiry (such as asking for a brochure), when You enter one of Our competitions, promotions or surveys, when you give Us information via email or online private mail systems, during a telephone conversation or online chat with Us, information you provide via our Website (such as registering as a user, booking, or posting on Our online forums), via social media messages or if You report something to Us such as a problem with Our Website.

From your travel agent

The information that We need from Your travel agent for Us to complete a booking or provide a personalised cruise plan for You is the same as We need when we obtain the personal data directly from You (see above).

From marketing sources

We love to receive new customers as a result of recommendations from Our existing customers, and We also actively seek new customers via marketing. We obtain personal data about prospective new customers from:

- You being on third party marketing lists, which We obtain via Webalytix Ltd, and which provides Us with contact details for You and an indication of why You may be interested in Our products or services;

- Your responses to Our online marketing or direct marketing to You, whether You respond by electronic mail, online chat, telephone, post, social media or other means;

- Your interactions with our online advertising (which is optimised to present our adverts to internet users who interact with Us via the internet) and advertisements placed by Our online advertising service providers. See Our Cookie Notice for information about Our service providers.

- We also use the same sources to learn more about Our existing customers, their preferences and interests, using information about where they visit on the internet.

From Our other service providers

We receive personal data about You from the following third parties who provide services to Us:

- Our bank or providers who process payments from You, to confirm the outcome of payment transactions;

- Other third parties in Viking's supply chain, Airlines, other carriers, Border control agencies, Contractors e.g. ship crews.

SPECIAL CATEGORY DATA WE COLLECT ABOUT YOU

Under the Data Protection Legislation the following categories of personal data, which We may collect from You, have special status (the "special category data"): personal data revealing racial or ethnic origin, political opinions, religious or philosophical beliefs, and genetic data, biometric data that uniquely identifies a living person, data concerning health, or data concerning a living person's sex life or sexual orientation, and data relating to actual or alleged crimes. We may obtain special category data when We collect it directly from You, or from Your travel agent. We do not obtain special category data from other third parties.

RECORDING AND MONITORING

In addition to storing written materials received from You and that we provide to You, and Our own records of our transactions and interactions with You, We may monitor and/or record: (1) telephone calls, (2) traffic data produced by electronic devices, applications and online services about the date and location of Your electronic activities with Us, and (3) Your online activities within Our control, including via social media traffic as well as via the Website. All recordings and derivative materials are and shall remain Our sole property.

CHILDREN

We do not provide products or services for purchase by children. If you are under 18, Your parents are responsible for providing Your personal data to Us.

HOW WE MAY CONTACT YOU

From August 2017 onwards, We have provided the ability for You to select and tell Us how You would like to be contacted by Us.

USE OF TOOLS/COOKIES

If Our contact and dealing with You is via the Website(s), or on third party online services where Our advertising is displayed, cookies may be used. Generally, Our cookies do not obtain or use personal data. However, if You permit cookies, We may process the following items of Your personal data using cookies:

- application cookies may assign a unique ID to Our Website registered users, and may record their approximate location;
- behavioural cookies may use Your historical transaction data;
- analytics cookies may assign a unique ID to Our Website visitors;
- marketing cookies will assign a unique ID to internet users.

To find out more about what types of cookies We use, how We use cookies, how to disable them or to change Your cookie preferences, please refer to our Cookies Notice.

YOUR CHOICES ABOUT WHAT WE COLLECT

To complete a booking, or to provide personalised cruise plans for You, as a minimum We need the following: Name and contact details, preferred destination and dates, facilities required on the cruise, whether You consider yourself to have a disability, medical needs and dietary needs. If You provide to Us personal data regarding Your medical needs and whether or not You consider Yourself to have a disability, this is special category data and We will only use it with Your consent.

This information may be given to third parties such as airlines, other carriers and ships to facilitate Your travel arrangements. If You prefer for Us to use less personal data, You can choose to make less available to Us.

HOW TO WITHHOLD PERSONAL DATA

You can control all of Our sources of Your personal data. You can:

- provide less personal data than We request;
- limit what personal data You give to Your travel agent;
- instruct Your travel agent to withhold items of personal data from Us;
- not respond to Our marketing and communications (and You also have rights to stop Our direct marketing to You: see below);
- change Your internet browser settings to prohibit cookies.

IMPACT OF WITHHOLDING PERSONAL DATA

Withholding Your personal data from Us will mean the updates, offers and communications (via advertisements, direct marketing or messages) You receive from Us are not personalised or relevant to You, or that You do not receive them at all. If You make an enquiry or booking with

Us, withholding Your personal data may mean that Our response to Your enquiry, and the booking (and thus your cruise), is not personalised or fully suitable for You. As We record all telephone calls, to avoid being recorded You will be unable to correspond with us by phone.

OUR USE OF YOUR PERSONAL DATA

For as long as We have access to Your personal data, We will use it for the following purposes, unless otherwise required as a result of You exercising Your data protection rights. We may use Your personal data for any of the following purposes, whether We obtained it directly from You (or someone You trust) or Your travel agent, or another source:

PURPOSE	LEGAL BASIS
(1) To provide You with Our services in accordance with Our contract with You, once You have completed a booking.	If you provide Us with special category data (such as your medical needs): We will ask You for explicit consent, and it is likely that We will be unable to process this special category data without Your consent. For Your other personal data: processing by Us, and by our Data Processors, is necessary for Us to perform the contract with You.
(2) To process Your payment for Our services.	Our legitimate interest in obtaining payment before performing Our contract with You.
(3) To provide You with information that You request from Us, or responding to Your enquiries made directly to Us or via Your travel agent.	Our legitimate interest in responding to Your requests and enquiries, e.g. by email, telephone, post or social media (or Your preferred one, if you tell us Your preferences).
(4) To understand and identify Your requirements of Us, by building a profile about You and Your preferences relevant to Your interest in cruises.	If you are an existing customer: Our legitimate interest in staying in touch with You, as part of Our after-cruise service and to seek repeat business.
(5) To send You solicited or unsolicited direct marketing (unless You ask Us to stop), consisting of relevant information about future cruises and similar services that We provide, such as offers of goods and services, brochures, new products, forthcoming events, loyalty programmes, clubs or competitions from Us or Our group companies.	If you are a prospective customer: Your consent for Us to obtain Your personal data and send unsolicited direct marketing to You. We may send notifications by e.g. by email, telephone, post or social media (or Your preferred one, if You tell us Your preferences). You can stop the above notifications at any time by contacting data.protection@viking.com
(6) To measure the effectiveness of Our advertising and marketing to You.	
(7) To ensure that features and content from the Website are available for You (if you choose to use them) and are presented in the most effective manner for You and for Your devices.	Our legitimate interest in providing products, services, choices, operations and Websites that meet the requirements of Our existing and prospective customers.
(8) To check and confirm that We carry out Your instructions accurately, to enable Us to review and improve Our products, services and operations and develop new and changed products, services and operations.	
(9) To carry out credit checking, services and operations and develop new and changed products, services and operations.	Our legitimate interest in assessing Your credit-worthiness before offering or committing to provide You with credit.
(10) To help Us detect and take action against security breaches, fraud and other crimes, and other risks to Us.	Our legitimate interest in addressing security breaches, frauds and other crimes or risks that may affect Our business.
(11) For Us to take legal or administrative action, including to collect debts, resolve disputes with You, and to deal with regulators.	In the case of personal data: Our legitimate interest in enforcing Our contract with You and in resolving any disputes with You and in dealing with regulators. In the case of special category data: as necessary for Us to establish, exercise or defend legal claims.
(12) To contact You by email.	For prospective customers: Normally We will ask for Your consent and will not contact You by email if You have specifically withheld or withdrawn Your consent to this. See above, "How We may contact You". For existing customers: It is lawful for Us to contact You by email provided that We give You an easy method to unsubscribe. You can stop Us contacting you by email at any time by contacting uk-marketing@viking.com or data.protection@viking.com .
(13) To contact You by telephone.	We will ask for Your explicit consent, and will not contact You by telephone unless We have Your consent, unless covered by legitimate interest.
(14) To transfer Your personal data overseas (see below).	We will ask for Your explicit consent and may be unable to process Your personal data unless We have Your consent.
(15) To use other people's personal data that You provide to Us.	Our legitimate interest in providing Our service to You. We do ask You to ensure that You have the other people's permission for You to share their personal data, and that You make them aware that You have shared it with Us for use as described in this Privacy Notice.

BOOKING CONDITIONS

HOW LONG WE RETAIN YOUR PERSONAL DATA

We will hold Your personal data until We find Your contact details are not current, or You can't be reached after 6 months of trying, or we are notified that You are deceased, or You or a regulator ask Us to stop processing Your personal data.

DISCLOSURE OF YOUR PERSONAL DATA

For as long as We have access to Your personal data, We may share any of it with any of the following to the extent that they need to have access to Your personal data in order to perform their role:

- (1) Anyone within Our organisation which includes, without limitation, Our sales and marketing teams, and Our finance team.
- (2) Other companies in Our group, such as Our parent company, Viking River Cruises (Bermuda) Ltd. When We store and use Your personal data in electronic format, We use IT systems that are operated by Our parent company, and located in the United States. See the section "Our transfer of your personal data abroad", below, for more information.
- (3) Selected third parties who help Us to perform Our contract with you. This includes third parties who help Us directly (such as airlines and service providers on the ship, which operate globally and both in the United Kingdom and Your intended cruise destination(s)), and third parties who help Us indirectly (such as our IT service providers, marketing mailing houses who may create and/or distribute Our marketing materials to You). We do not share Your personal data with third parties for their own marketing purposes. We may provide You with services from third party suppliers.
- (4) Your travel agent.
- (5) Our banks and other payment processing service providers who process Your payments to Us.
- (6) The law enforcement authorities of the United Kingdom and other jurisdictions, and in particular their border control, anti-terrorism and related functions. See the section "Our transfer of your personal data abroad", below, for more information.
- (7) Our IT service providers who provide, maintain, improve, manage, optimise or fix the IT facilities that We use or rely on in our business, including computing devices, computer networks, connectivity, telecommunications, software, our Website.
- (8) Our online service providers, who provide marketing and advertising placement services for Us, including providers of search engines, analytics services, behavioural marketing services, and online applications and services including social media.
- (9) Our professional service providers, such as accountants, auditors and insurance brokers.
- (10) Credit reference agencies that We use to assess Your credit score where this is a condition of Us entering into a contract with You.
- (11) Your and Our insurers and their agents, and Your and Our medical staff and legal advisers.
- (12) Any third party company or companies in the event that We go through a business transition, such as a merger, being acquired by another person or company, or selling a portion of Our assets.

We reserve the right to disclose Your personal data to other third parties if We have lawful grounds to do so, or are under a legal obligation to disclose or share it with them, or in order to establish, exercise or defend Our legal rights, or to protect the rights, property, or safety of the Company. This includes exchanging information with other companies and organisations for the purposes of fraud protection and credit risk reduction.

OUR TRANSFER OF YOUR PERSONAL DATA ABROAD

As stated above, in some cases We will transfer Your personal data to a location that is outside the United

Kingdom. Decisions as to, whether or not States outside the European Economic Area have "adequate" safeguards for personal data will be made in accordance with Data Protection Legislation. In the absence of such decisions, the transfer of Your personal data outside the UK or EEA can still be lawful if safeguards are in place, or if We have Your explicit consent or some other permission recognised by GDPR.

- In the case of the United States, it is not currently considered to provide adequate safeguards. We have a contract in place with Our parent company to safeguard Your personal data.
- If Your intended cruise destination(s) is/are outside the United Kingdom, the relevant state(s) may not provide adequate safeguards. We can lawfully make necessary transfers of Your personal data to these overseas locations if We have Your explicit consent. If We ask You for Your explicit consent, it may be the case that We will be unable to make the necessary transfer(s) of Your personal data to these overseas locations unless We obtain Your consent. This may impact on Our ability to process Your personal data using Our electronic systems, and/or it may result in You being denied entry to Your intended cruise destination(s).
- In the case of the United States, it is not currently considered to provide adequate safeguards, although its Government operates Privacy Shield and members of that scheme are considered to have "adequate" safeguards.
- If Your intended cruise destination(s) is/are outside the European Economic Area, the relevant state(s) may not provide adequate safeguards.

We can lawfully make necessary transfers of Your personal data to these overseas locations if We have Your explicit consent. If We ask You for Your explicit consent, it may be the case that We will be unable to make the necessary transfer(s) of Your personal data to these overseas locations unless We obtain your consent. This may impact on Our ability to process Your personal data using Our electronic systems, and/or it may result in You being denied entry to Your intended cruise destination(s).

YOUR RIGHTS UNDER THE DATA PROTECTION LEGISLATION:

- (1) You have the right to access personal data that We hold about You. Your right of access can be exercised in accordance with the Data Protection Legislation. You can submit a data access request at any time. In order to do this, please contact Us at data.protection@viking.com.
- (2) If You become aware of any inaccuracies in Your personal data which We process on Your behalf, You have a right to ask Us to rectify the inaccuracies. On receiving Your request We will either fulfil it or explain why We have decided not to.
- (3) To the extent that (a) We no longer need to use Your personal data (e.g. You no longer wish to receive marketing from Us, or You tell us that You no longer wish to go on cruises) for purposes described in our Notices, or (b) We rely on Your consent and You have withdrawn it, or (c) You object to Our legitimate interests for using Your personal data and no exception applies to permit Us to keep using it, or (d) it is established that We did not have the lawful right to process Your personal data, or (e) the law requires Us to erase Your personal data, You may ask Us to erase Your personal data. If we erase Your personal data, Your ability to use Our services will be affected, as described above.
- (4) You have the right to ask Us not to process Your personal data for marketing purposes (including profiling). You may unsubscribe at any time by emailing Us directly at data.protection@viking.com.
- (5) You have the right to object to Our processing of Your personal data to the extent that (a) We use the personal data on grounds of Our legitimate interests and no exception applies to permit Us to keep using it, or (b) We use it for direct marketing purposes, or (c) We use it for scientific or historical research purposes or statistical purposes and no exception applies to permit Us to keep using it.

(6) You have the right to ask Us to restrict Our processing of your personal data to the extent that (a) You have questioned the accuracy of the personal data and We are still checking its accuracy, (b) it is established that We did not have the lawful right to process the personal data, (c) We no longer need to use Your personal data for the purposes We collected or used it for but You need it to be preserved for the purposes of legal claims, or (d) You have exercised Your right to object to Our use of your personal data and no exception applies to permit Us to keep using it.

(7) You have the right to request that We provide to You, or to another data controller on Your behalf, a copy of any of Your personal data which We process using automated means based on your consent, so that You may reuse such personal data for Your own purposes on alternative services.

(8) You have the right not to be subject to automated processing which significantly affects You, unless We need to carry out the automated decision-making to enter into or perform Our contract with You, or We are authorised by law to use the personal data for automated decision-making, or We have Your explicit consent.

(9) You have the right to complain to the Information Commissioner (www.ico.org.uk) if You have any concerns in respect of the handling of Your personal data by the Company.

If You would like to exercise any of the above rights, including to withdraw Your consent (where Our processing of Your personal information relies on Your consent), please contact Us at data.protection@viking.com.

OUR PROTECTION OF YOUR PERSONAL INFORMATION

We have taken reasonable steps to put in place appropriate security measures to protect Your personal data when it is processed by Us or on our behalf.

We do not accept any responsibility for the policies of third party Data Controllers, such as providers of search engines and social media services. Your use of such third parties, their websites and services is at Your own risk.

Please check the third parties' Privacy Notices before You submit any personal data to them.

CHANGES TO PRIVACY NOTICE

We reserve the right to make changes to this Privacy Notice from time to time. If this Privacy Notice changes in any way, We will place an updated version on our Website. Regularly reviewing our Website ensures that You are always aware of what information We collect, how We use it and under what circumstances, if any, We will share it with other parties.

If You do not agree to the changes that we make from time to time, please tell Us via data.protection@viking.com. If material changes are made to this Privacy Notice, We will notify You by placing a prominent notice on the Website.

YOUR COMMENTS ARE APPRECIATED

If You have any questions or comments regarding the Privacy Notice, You can send Us an email at data.protection@viking.com.

Information in this brochure is correct at the time of going to print on 6th November 2023. For the most up-to-date booking conditions please visit www.viking.com/legal or call us.

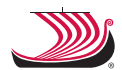

VIKING

Exploring the World in Comfort



When you are named #1 for Rivers...



A Viking Longship near Aschaffenberg, Germany



#1 for Oceans...



Viking Star near Flåm, Norway



and #1 for Expeditions,
Where do you go next?



Viking Polaris in Antarctica

Onwards.

Now it is time for us to work even harder.



VIKING

Exploring the World in Comfort®



 **RiverCruising.co.uk**
THE RIVER CRUISE EXPERTS

Viking | Nelsons House | 83 Wimbledon Park Side | London | SW19 5LP

For reservations or information, call **RiverCruising.co.uk** on **0800 810 8262**. Our Reservations department is open 7 days a week.



Terms and conditions: Offers apply to new bookings only and can be withdrawn at any time. All departures are subject to availability. Prices and availability are correct at the time of going to print but are subject to change. Please call for details. £100pp Viking Explorer Society loyalty discount applies only to guests who have previously travelled with Viking and cannot be applied to new Viking guests. From prices on Viking ocean and expedition journeys are based on two people sharing the lowest grade stateroom, departing on selected dates in 2025. From prices on Viking river cruises are based on two people sharing the lowest grade stateroom, departing on selected 2025 dates. £1,000pp early booking discount is only valid on 2025 European river journeys and offer does not apply to Viking Egypt, Mississippi and Mekong cruises. £1,000 early booking discount is valid until 30 June 2024 and is only valid on 2025 European river cruises. Port sequences, places visited, tours and times may vary or be different to those shown in the brochure. All prices are per person based on double occupancy. Single supplements apply. All offers can be withdrawn at any time. Flights from local airports will be booked by Viking's air department. These flights may be indirect, involve a change of aircraft and can depart as early as 6am. Please note that while only scheduled airlines are used, some may charge for luggage.

If you would no longer like to receive marketing communications from Viking, please call us on 020 8780 7900 or write to us at Viking, Nelsons House, 83 Wimbledon Park Side, London, SW19 5LP and you will be unsubscribed from our mailing list. All of our incoming and outbound calls are recorded to help provide the highest standards of customer care. If you do not wish to have your call recorded, please contact us via our website viking.com. Our latest privacy notice can be found at viking.com. The privacy notice tells you what information we collect about you, how we use it, and your related rights.



ATOL protected. 'Viking', 'Viking Cruises', 'Viking River Cruises', 'Viking Ocean Cruises' and 'Viking Expeditions' are trading names of Viking River Cruises UK Limited. ATOL number 3124. All the flights and flight-inclusive holidays in this brochure are financially protected by the ATOL scheme. When you pay you will be supplied with an ATOL Certificate. Please ask for it and check to ensure that everything you booked (flights, hotels and other services) is listed on it. Please see our booking conditions for further information or for more information about financial protection and the ATOL Certificate go to: www.atol.org.uk/ATOLCertificate, call us on 020 8780 7900 or see your travel agent.



RiverCruising.co.uk

THE RIVER CRUISE EXPERTS

FOR THE LATEST PRICES AND AVAILABILITY
CALL OUR TEAM ON **0800 810 8262**

TO ORDER A COPY OF THIS BROCHURE
EMAIL: **BROCHURES@RIVERCRUISING.CO.UK**

(BROCHURES SUBJECT TO STOCK)